

DESCRIPTION

RangeMAX Wide Range Dimming, Quad Output Inverter. The LXM1641 Direct Drive™ CCFL (Cold Cathode Fluorescent Lamp) Inverter Modules are specifically designed for driving LCD backlight lamps.

Similar to the LXM1640, the LXM1641 excels in applications where critical parameters include very wide range dimmability, high efficiency and reliable fail-safe design in a small form factor. These 12 volt input modules are specifically designed with desktop and industrial applications in mind.

Unlike the LXM1640 or any traditional dimming CCFL inverters, the LXM1641 provides the designer a vastly superior display brightness range. 1000:1+ brightness range is achievable with a standard LCD display (see Application Section). Our wide range dimming provides exceptional display readability at less than 1% of full brightness, allowing both power savings and low ambient light operating capability (i.e. "night readable").

RangeMAX Digital Dimming Technique. Digital dimming provides flicker-free brightness control in any wide-range dimming application. Dimming ratios greater than 1000:1 can be achieved. Incorporation of a video synchronization feature allows wide ratio dimming without the display disturbances and interference seen with competitive products.

The modules are equipped with a dimming input that permits brightness control from an external potentiometer or DC voltage source. The resultant "burst drive" that energizes the

lamp was designed specifically to ensure that no premature lamp degradation occurs (see "How RangeMAX Works" Section).

Failsafe Feature For Multiple Lamp Applications. Our multi-output inverters are designed to keep your application operating at near normal brightness in the event that a lamp fails. This allows the display to remain "on-line" until lamp replacement is convenient.

Direct Drive Technology. The module design is based on a new patented¹ Direct Drive topology, which provides a number of cost and performance advantages. The LXM1641-xx Direct Drive inverters eliminate the classic resonant inductor and capacitors, thus reducing cost and allowing a substantial reduction in module size.

Universal Connector Configuration. Linfinity's multiple lamp inverters include a built in connector array for the most common LCD lamp configurations.

Additional Features. Other benefits of this new topology are fixed-frequency operation and secondary-side strike-voltage regulation.

Strike-voltage regulation minimizes corona discharge in the output transformer and related circuitry, providing longer life and higher reliability. All LXM1641 modules feature both open and shorted lamp protection.

The LXM1641 is fully customizable (electronically and mechanically) to specific customer requirements.

¹US Patent Numbers: 5923129 & 5930121

KEY FEATURES

- RangeMAX Wide Range Dimming
- 8V to 16V Input Voltage Range
- Small Form Factor
- Easy To Use Brightness Control
- MicroAmp SLEEP Mode
- Output Short-Circuit Protection And Automatic Strike-Voltage Regulation
- Fixed Frequency Operation
- Universal Connector Configuration

APPLICATIONS

- Hi-Brite Displays
- Desktop Displays
- Low Ambient Light Conditions (i.e. Aircraft Cabins, Automobile)
- Industrial Applications

BENEFITS

- High Efficiency Reduces Heating Problems
- Smooth, Flicker Free 0-100% Full-Range Brightness Control Gives Your Product A High Quality Image
- Output Open Circuit Voltage Regulation Minimizes Corona Discharge For Long Life And High Reliability
- Power Efficient, "Low Brightness" Capability Allows For Advanced Power Management

NOTE: For current data & package dimensions, visit our web site: <http://www.linfinity.com>.

MODULE ORDER INFORMATION

Part Number	Application	Inverter Mates Directly to Panel Connectors
LXM1641-01*	Quad Lamp Panels	JST BHR-03VS-1 (3-pin) & JST BHR-04VS-1 (4-pin)
LXM1641-02*	Sharp 18.1" Panel	JST XHP-9 (9-pin)
LXM1641-03	LG Electronics 18.1" Panel	JST BHSR-02VS-1 (2-pin)

* UL60950 E175910

DIGITAL DIMMING QUAD LAMP CCFL INVERTER MODULE

PRELIMINARY DATA SHEET

ABSOLUTE MAXIMUM RATINGS (Note 1)

Input Supply Voltage (V_{IN})	-0.3V to 16V
Output Voltage, no load	Internally Limited to $1800V_{RMS}$
Output Current	$10.0mA_{RMS}$ (Internally Limited)
Output Power (per Lamp)	6.0W
Input Signal Voltage (BRITE Input)	-0.3V to 6.5V
Input Signal Voltage (SLEEP, V_{SYNC} Inputs)	-0.3V to V_{IN}
Ambient Operating Temperature	0°C to 50°C
Storage Temperature Range	-40°C to 85°C

Note 1. Exceeding these ratings could cause damage to the device. All voltages are with respect to Ground. Currents are positive into, negative out of the specified terminal.

RECOMMENDED OPERATING CONDITIONS (R.C.)

This module has been designed to operate over a wide range of input and output conditions. However, best efficiency and performance will be obtained if the module is operated under the condition listed in the 'R.C.' column. Min. and Max. columns indicate values beyond which the inverter, although operational, will not function optimally.

Parameter	Symbol	Recommended Operating Conditions			Units
		Min.	R.C.	Max.	
Input Supply Voltage Range (Functional)	LXM1641-01, -02 LXM1641-03	8 10	12 12	16 14	V
Input Supply Voltage (Fully Regulated Lamp Current)	LXM1641-01, -02 LXM1641-03	9 10.8	12 12	16 13.2	V
Output Power (per Lamp)	P_O		4	5	W
Brightness Control Input Voltage Range	$V_{BRT\ ADJ}$	0.0		2.5	V
Lamp Operating Voltage	V_{LAMP}	300	675	800	V_{RMS}
Lamp Current (Full Brightness - per Lamp)	I_{OLAMP}		7.0		mA_{RMS}
Operating Ambient Temperature Range	T_A	0		70	°C

ELECTRICAL CHARACTERISTICS

Unless otherwise specified, these specifications apply over the recommended operating conditions and 25°C ambient temperature for the LXM1641.

Parameter	Symbol	Test Conditions	LXM1641-xx			Units
			Min.	Typ.	Max.	
Output Pin Characteristics						
Full Bright Lamp Current (per Lamp)	$I_L (MAX)$	$V_{BRT\ ADJ} = 2.5V_{DC}$, SLEEP = HIGH, Burst Duty = 100%, $V_{IN} = 9V_{DC}$	6.3	7.0	7.7	mA_{RMS}
		$V_{BRT\ ADJ} = 2.5V_{DC}$, SLEEP = HIGH, Burst Duty = 100%, $V_{IN} = 12V_{DC}$	7.2	8.0	8.8	mA_{RMS}
Minimum Lamp Current (per Lamp) (Notes 2 & 3)	$I_L (MIN)$	$V_{BRT\ ADJ} = 0V_{DC}$, SLEEP = HIGH, Burst Duty = 2%, $V_{IN} = 9V_{DC}$		0.14		mA_{RMS}
		$V_{BRT\ ADJ} = -50mV_{DC}$, SLEEP = HIGH, Burst Duty = 0.5%, $V_{IN} = 9V_{DC}$		0.035		mA_{RMS}
Lamp Start Voltage	V_{LS}	0°C < T_A < 40°C, $V_{IN} \geq 10.8V_{DC}$	1500		1800	V_{RMS}
Operating Frequency	f_O	$V_{BRT\ ADJ} = 2.5V_{DC}$, SLEEP = HIGH, $V_{IN} = 12V_{DC}$	52	57	62	KHz
BRITE Input						
Input Current	I_{BRT}	$V_{BRT\ ADJ} = 0V_{DC}$	-6	-8	-10	μA_{DC}
Input Voltage for Max. Lamp Current	V_C	$I_O (LAMP) = 100\%$ Duty Cycle		2.5	2.6	V_{DC}
Input Voltage for Min. Lamp Current (Note 3)	V_C	$I_O (LAMP) = 2\%$ Duty Cycle		0	0	V_{DC}
		$I_O (LAMP) = 0.5\%$ Duty Cycle		-50		mV_{DC}
SLEEP Input						
RUN Mode	$V_{SLEEP (HI)}$		2.2		V_{IN}	V_{DC}
SLEEP Mode	$V_{SLEEP (LO)}$		-0.3		0.8	V_{DC}
Input Current	I_{SLEEP}	SLEEP = 5.0V	70	75	100	μA_{DC}

Note 2. Minimum lamp current required to maintain even light output may vary with display panel.
 Note 3. See 1000:1 Dimming Application section for details.

DIGITAL DIMMING QUAD LAMP CCFL INVERTER MODULE

PRELIMINARY DATA SHEET

ELECTRICAL CHARACTERISTICS (Continued)

Parameter	Symbol	Test Conditions	LXM1641-xx			Units
			Min.	Typ.	Max.	
V_{SYNC} Characteristics						
Logic High Level	V _{SYNC (HI)}		4.0		6.5	V _{DC}
Logic Low Level	V _{SYNC (LO)}		-0.3		1.0	V _{DC}
Input Impedance	Z _{IN}		60	66	75	kΩ
Pulse Width (Note 4)	t _{PW}		25		250	μs
Input Frequency	f _{SYNC}		49		150	Hz
Power Characteristics						
Sleep Current	I _{IN (MIN)}	V _{IN} = 12V _{DC} , SLEEP ≤ 0.8V		5	50	μA _{DC}

Note 4. The module will be functional with pulse widths much larger than 250μs, but will have limited dimming.

NOT RECOMMENDED FOR NEW DESIGNS

DIGITAL DIMMING QUAD LAMP CCFL INVERTER MODULE

PRELIMINARY DATA SHEET

PHYSICAL DIMENSIONS

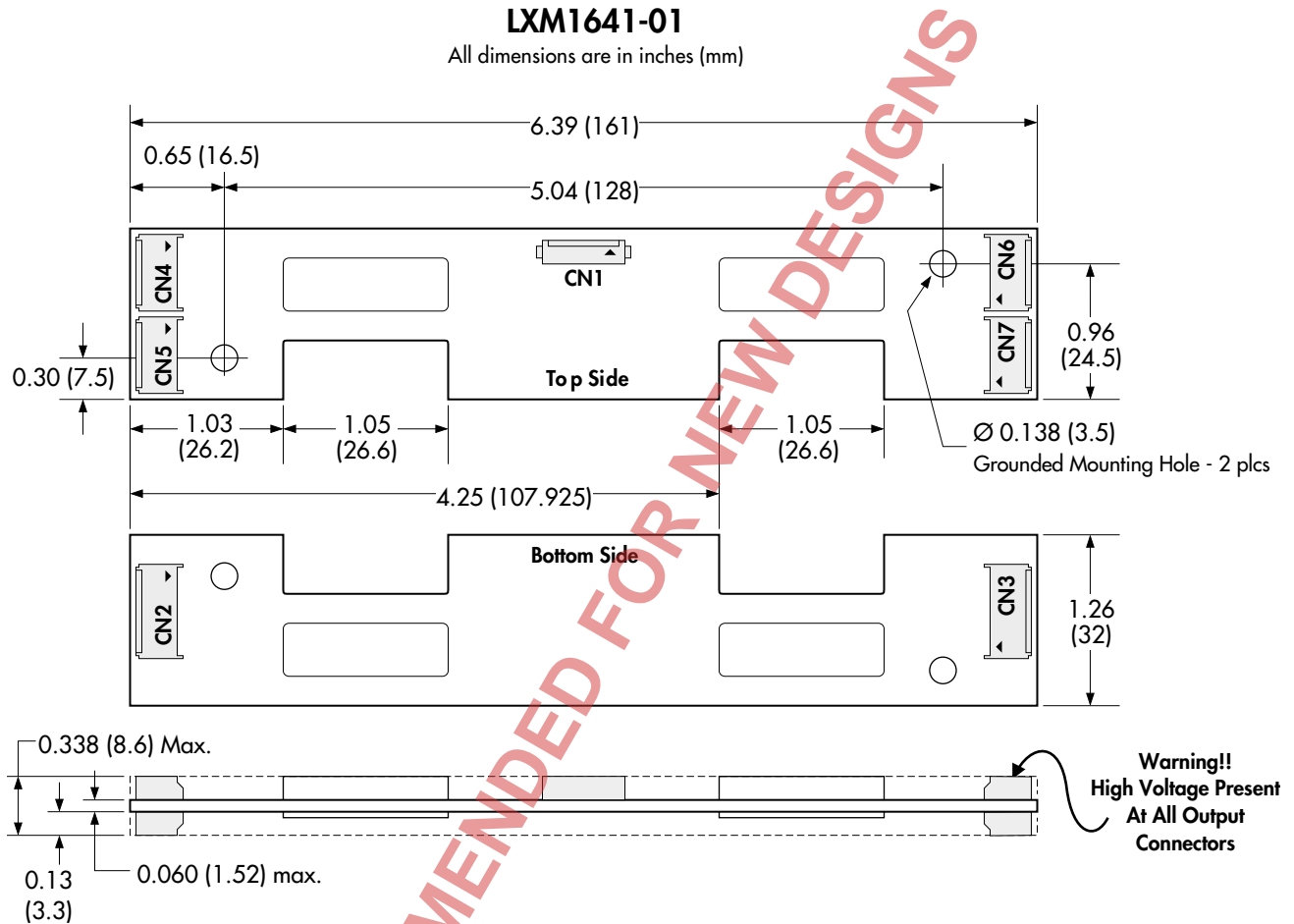

Functional Pin Description

Conn.	Pin	Description
CN1		
CN1-1, 2	V_{IN}	Input Power Supply. ($8V \leq V_{IN} \leq 16V$)
CN1-3, 4	GND	Power Supply Return.
CN1-5	\overline{SLEEP}	ON/OFF Control. ($2.2V < \overline{SLEEP} < V_{IN} = ON$, $-0.3V < \overline{SLEEP} < 0.8V = OFF$)
CN1-6	BRITE	Brightness Control ($-0.3V$ to $2.5V_{DC}$). $2.5V_{DC}$ gives maximum lamp current.
CN1-7, 8	V_{SYNC}	Vertical synchronization input. $49Hz < f_{SYNC} < 150Hz$
CN2 thru CN7: Refer to Figure 2		

CONNECTOR SCHEMATIC

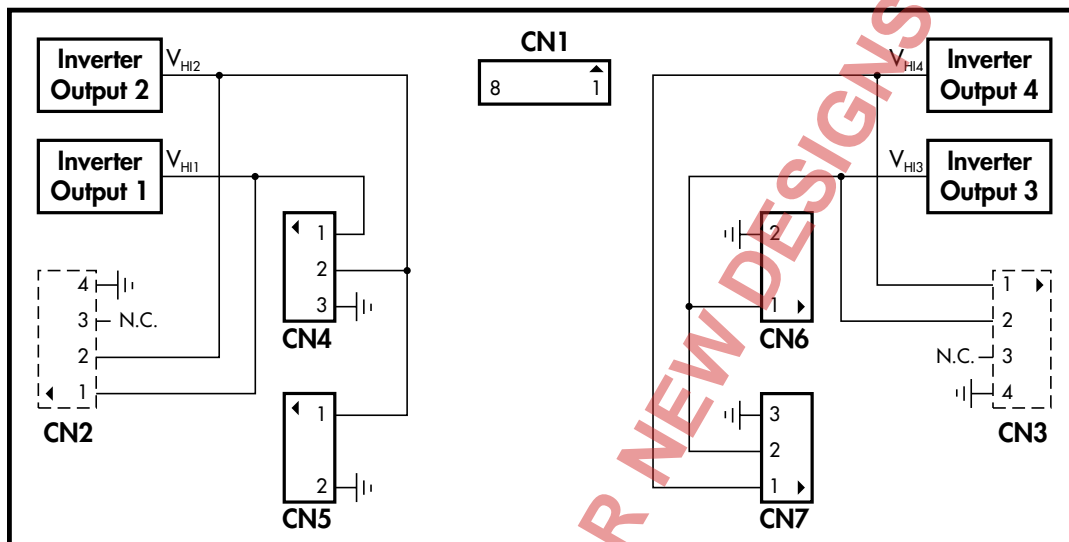

FIGURE 2 — LXM1641-01 Connector Schematic

Note: CN2 and CN3 (shown with dashed lines) are located on the opposite side of the PCB from CN1, CN4, CN5, CN6, and CN7. Their pin numbers are shown as viewed looking through the printed circuit board.

Connectors:

CN1 = MOLEX 53261-0890

CN2, CN3 = JST SM04(4.0)B-BHS-1-TB

CN4, CN7 = JST SM03(4.0)B-BHS-1-TB

CN5, CN6 = JST SM02(8.0)B-BHS-1-TB

Mates With:

Pins: 50079-8100*, Housing: 51021-0800

* Loose (-8000, Chain) Recommended #26 AWG wiring

JST BHR-04VS-1

JST BHR-03VS-1

JST BHR-03VS-1

Connection Rules

1. Always install FOUR (4) lamps. Operating with fewer lamps may overdrive lamp current at maximum brightness settings.
2. Verify lamp wiring before connecting lamps to the inverter module. Connecting multiple lamps to one of the four inverter output circuits will result in reduced brightness. The LXM1641-01 module connectors are wired per industry standard. The lamp **hot** wires (high voltage wires) are always on pin 1 or 2, and the **cold** wire (low voltage wire) is always on pin 3 or 4.

DIGITAL DIMMING QUAD LAMP CCFL INVERTER MODULE

PRELIMINARY DATA SHEET

PHYSICAL DIMENSIONS

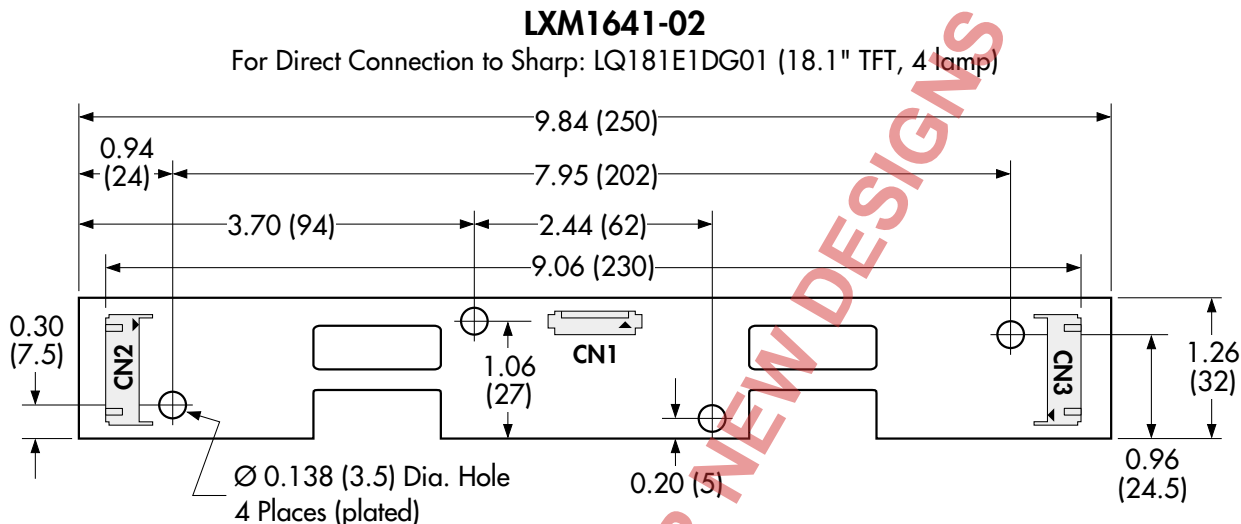

FIGURE 3 — LXM1641-02 Physical Dimensions
All dimensions are in inches (mm)

Connectors:

CN1 = MOLEX 53261-0890
CN2, CN3 = JST S9B-XH-A

Mates With:

Pins: 50079-8100, Housing: 51021-0800
XHP-9

Functional Pin Description

Connector Pin #	Pin Name	Description
CN1-1, 2	V _{IN}	Input Power Supply (8V to 16V)
CN1-3, 4	GND	Power Supply Return
CN1-5	SLEEP	ON / OFF Control (2.2V < SLEEP < V _{IN} = ON, -0.3V < SLEEP < 0.8V = OFF)
CN1-6	BRITE	Brightness Control (-0.3V to 2.5V), 2.5V gives max. lamp current
CN1-7, 8	V _{SYNC}	Vertical Sync Input, negative going. 49Hz < f _{SYNC} < 150Hz
CN2-1	V _{HI1}	High-voltage connection to high side of lamp 1
CN2-2, 3	N.C.	No Connect
CN2-4	V _{HI2}	High-voltage connection to high side of lamp 2
CN2-5, 6	N.C.	No Connect
CN2-7	V _{LO}	Connection to low side of lamp 2
CN2-8	N.C.	No Connect
CN2-9	V _{LO}	Connection to low side of lamp 1
CN3-1	V _{HI3}	High-voltage connection to high side of lamp 4
CN3-2, 3	N.C.	No Connect
CN3-4	V _{HI4}	High-voltage connection to high side of lamp 3
CN3-5, 6	N.C.	No Connect
CN3-7	V _{LO}	Connection to low side of lamp 3
CN3-8	N.C.	No Connect
CN3-9	V _{LO}	Connection to low side of lamp 4

PHYSICAL DIMENSIONS

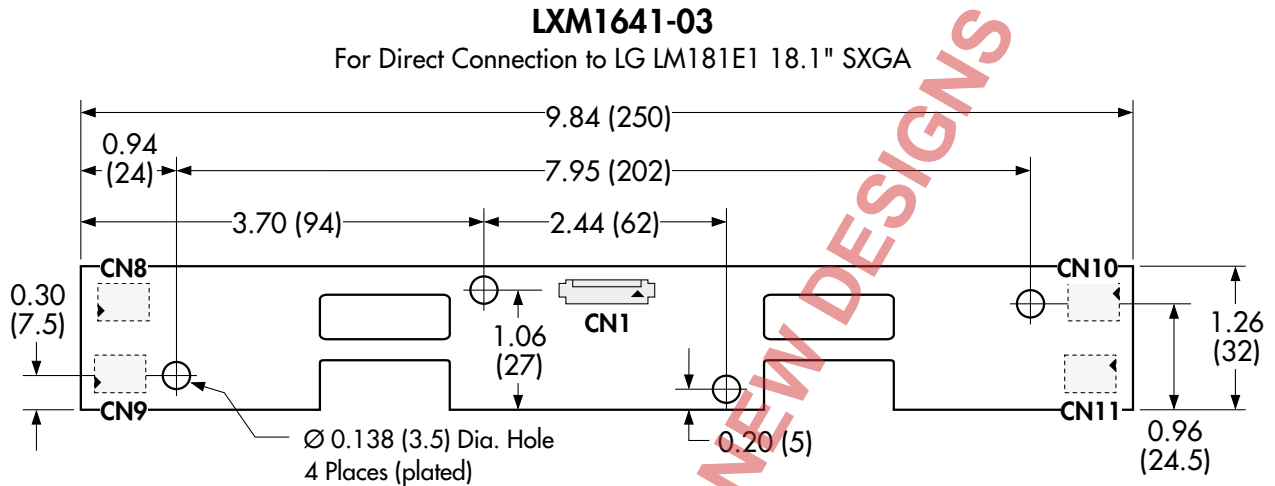

FIGURE 4 — LXM1641-03 Physical Dimensions
All dimensions are in inches (mm)

Connectors:

CN1 = MOLEX 53261-0890

CN8, CN9, CN10, CN11 = JST SM02B-BHSS-1-TB

Mates With:

Pins: 50079-8100, Housing: 51021-0800

BHSR-02VS-1

Functional Pin Description

Connector Pin #	Pin	Description
CN1-1, 2	V _{IN}	Input Power Supply (10V to 14V)
CN1-3, 4	GND	Power Supply Return
CN1-5	SLEEP	ON / OFF Control (2.2V < SLEEP < V _{IN} = ON, -0.3V < SLEEP < 0.8V = OFF)
CN1-6	BRITE	Brightness Control (-0.3V to 2.5V), 2.5V gives max. lamp current
CN1-7, 8	V _{SYNC}	Vertical Sync Input, negative going. 49Hz < f _{SYNC} < 150Hz
CN8-1	V _{H1}	High-voltage connection to high side of lamp 1
CN8-2	V _{LO}	Connection to low side of lamp 1
CN9-1	V _{H1}	High-voltage connection to high side of lamp 2
CN9-2	V _{LO}	Connection to low side of lamp 2
CN10-1	V _{H1}	High-voltage connection to high side of lamp 3
CN10-2	V _{LO}	Connection to low side of lamp 3
CN11-1	V _{H1}	High-voltage connection to high side of lamp 4
CN11-2	V _{LO}	Connection to low side of lamp 4

DIGITAL DIMMING QUAD LAMP CCFL INVERTER MODULE

PRELIMINARY DATA SHEET

TYPICAL CONNECTION CONFIGURATIONS

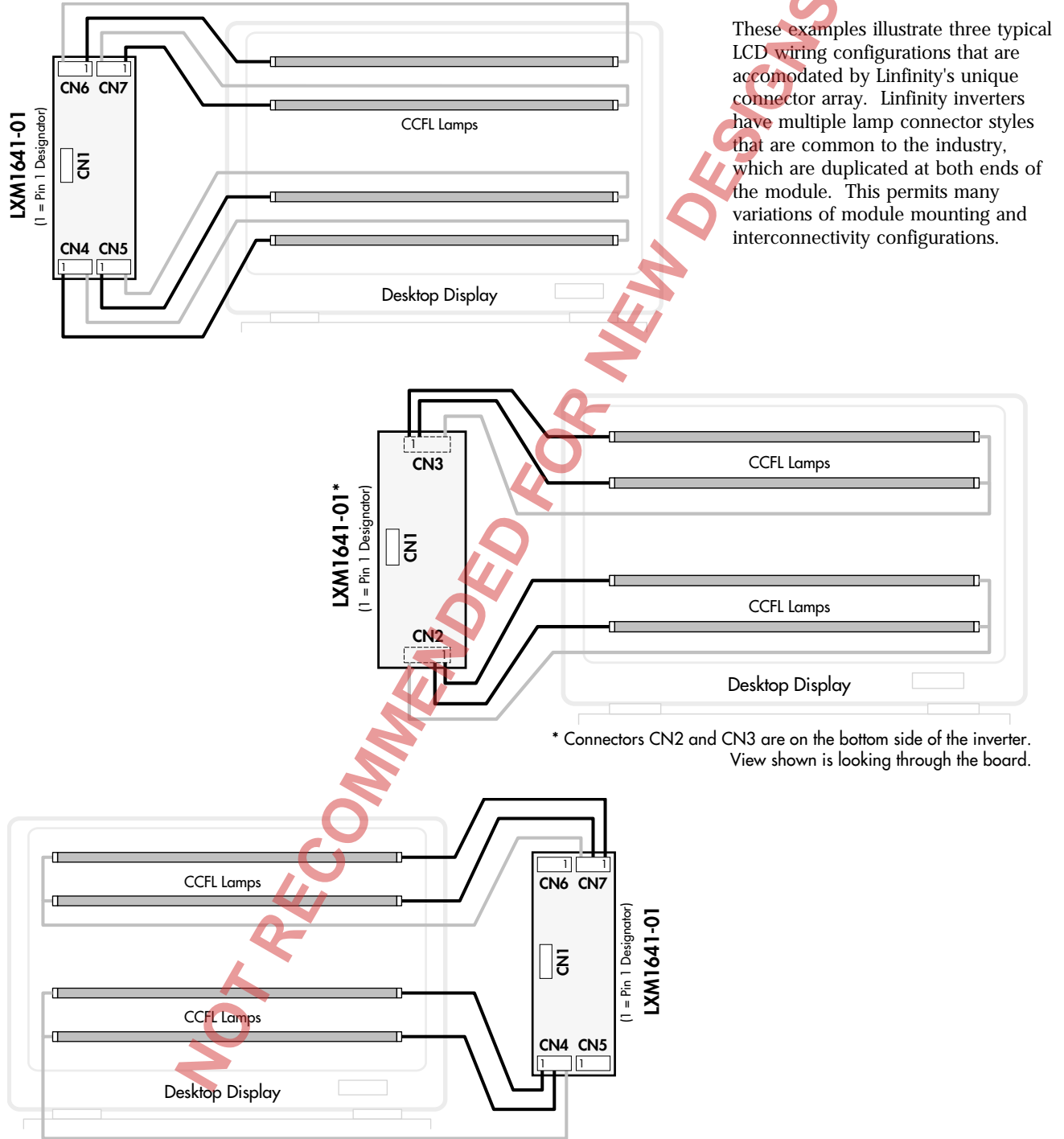

FIGURE 5 — Connectivity Configuration Examples

HOW RANGEMAX WORKS

LAMP VOLTAGE & LAMP CURRENT — Burst Mode Operation

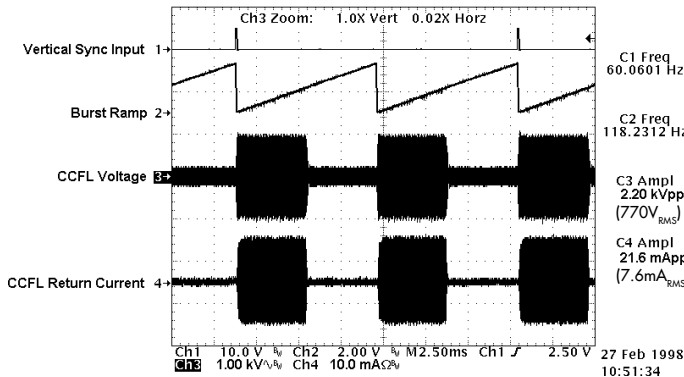

FIGURE 6 — 50% Burst Duty Cycle

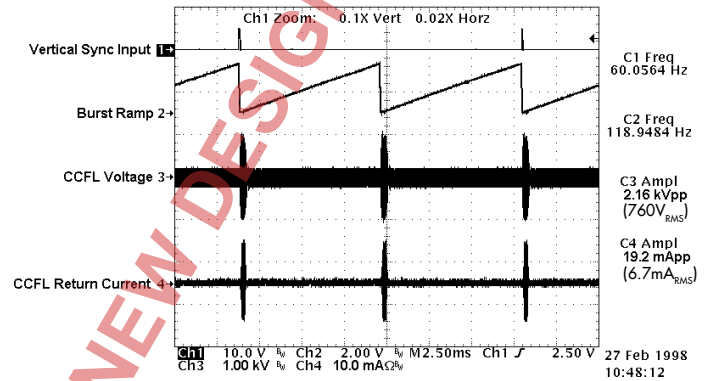

FIGURE 7 — 2% Burst Duty Cycle

Rather than using the traditional dimming technique of varying lamp current magnitude to adjust light output, RangeMAX inverters use a fixed lamp current value with a duty cycle control method.

The lamp current burst width can be modulated from 100% (continuous lamp current) down to a 2% duty cycle, allowing the lamp to be dimmed to less than 1% of its full brightness.

As can be seen in Trace 4 of Figure 8, careful design consideration was given to controlling lamp start voltage to softly start current flow. This eliminates current overshoot that can result in premature cathode wear and reduce lamp life.

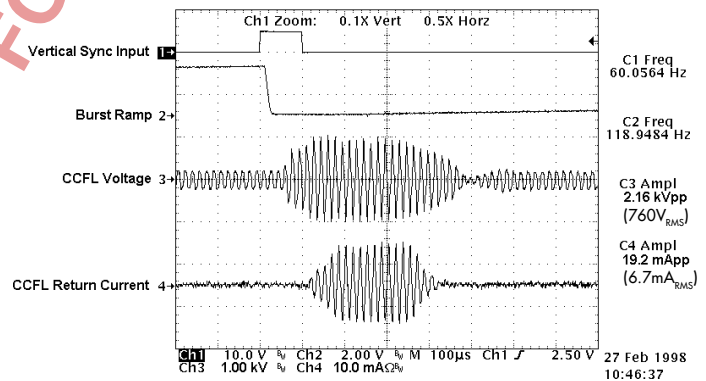

FIGURE 8 — 2% Burst Duty Cycle (Expanded Time Base)

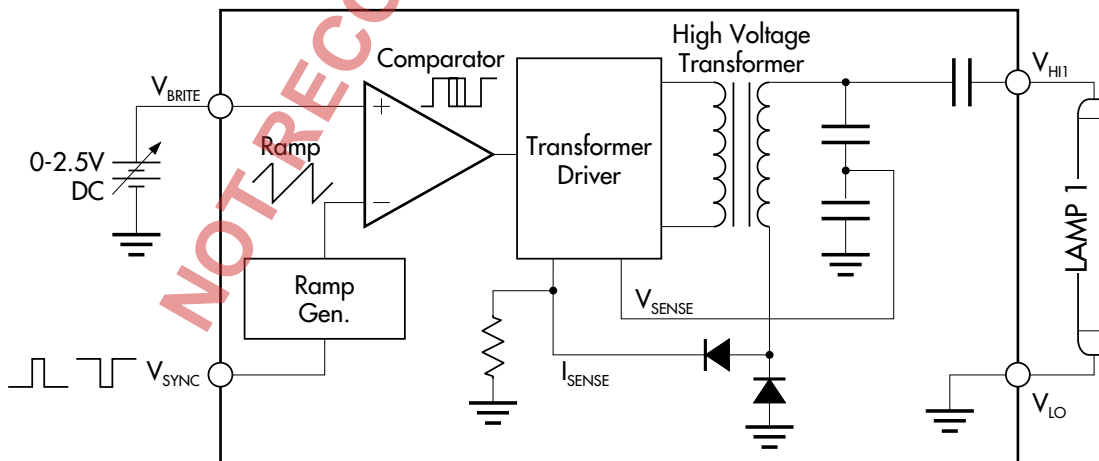

FIGURE 9 — RangeMAX Block Diagram

DIGITAL DIMMING QUAD LAMP CCFL INVERTER MODULE

PRELIMINARY DATA SHEET

HOW RANGEMAX WORKS (continued)

HIGHLIGHTS

- On-board brightness control circuit includes a DC voltage to pulse width converter that minimizes system design work and system noise susceptibility. This provides a familiar and convenient interface while reducing the potential for externally induced noise which can cause lamp flicker.
- An on-board oscillator operates the inverter BURST rate above 95Hz, well beyond standard 50/60Hz video refresh rates where the eye can perceive pulsing light.
- RangeMAX inverter modules are designed to operate with the burst frequency synchronized to the video frame rate. This provides operation with no visible display disturbances caused by beat frequencies between the lamps and video frame rates.
- In applications with no access to a vertical sync, the inverter burst frequency can be allowed to "free run" at 95Hz. In this non-synchronous mode, minor display disturbances may be found under certain video conditions. This performance is acceptable for many applications, but synchronization must be used when no disturbance can be tolerated.
- Separate feedback loops for lamp current and open circuit voltage regulation insure reliable strike under all operating conditions, automatic over-voltage prevention with broken or failed lamps, and accurate lamp current regulation.

TYPICAL 100:1 DIMMING APPLICATION

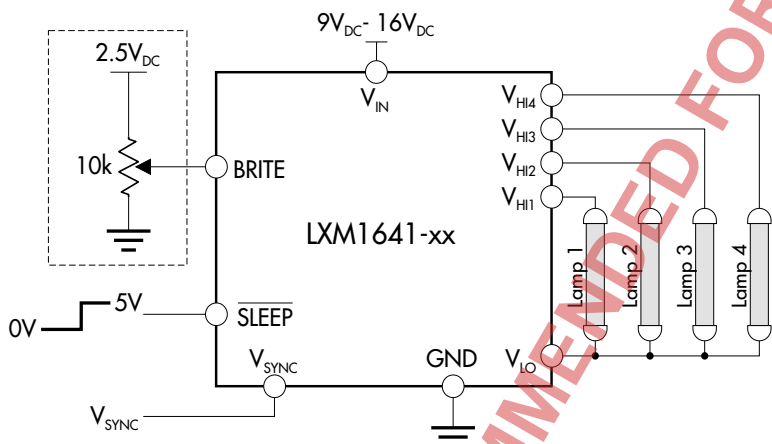
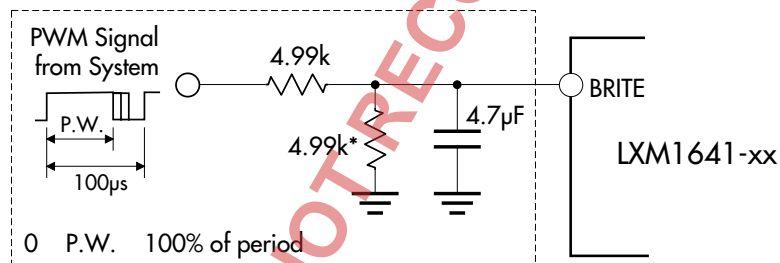

FIGURE 10 — Potentiometer Brightness Control



* use 4.99k for 5V PWM amplitude, 15k for 3.3V PWM amplitude, and omit for 2.5V PWM amplitude.

FIGURE 11 — PWM Brightness Control

- The brightness control may be a simple 10k potentiometer or a voltage output DAC. A PWM signal from a micro-controller may also be used with a suitable filter such as shown in Figure 11.
- If synchronization to the video framerate is desired, connect the vertical sync pulse from the system video controller to the appropriate V_{SYNC} input. If no video synchronization is desired, connect V_{SYNC} to ground.
- If you need to turn the inverter ON/OFF remotely, connect a 3V or 5V logic signal to the SLEEP input. If remote ON/OFF is not needed, connect the SLEEP input to V_{IN} or any other voltage greater than $2.2V_{DC}$.
- Connect V_{HI} to high voltage wire from the lamp. Connect V_{LO} to the low voltage wire (wire with thinner insulation). If both lamp wires have heavy high voltage insulation, connect the longest wire to V_{LO} . V_{LO} is connected directly to ground (GND pin) on the inverter PCB. Always insure a good lamp return by using a wire. Do not rely on a chassis ground connection.

DIGITAL DIMMING QUAD LAMP CCFL INVERTER MODULE

PRELIMINARY DATA SHEET

1000:1 DIMMING APPLICATION

The following application defines techniques capable of delivering dimming ranges in the 250:1 and 1000:1 range. As is widely understood, these techniques will provide general capabilities and actual system performance will vary with panel design, CCFTs, ambient temperature and a number of other variables outside the control of the inverter. These methods can be used in conjunction with other techniques such as lamp heating and matching.

Wide ratio (1000:1) dimming can be accomplished using the Linfinity inverter in two ways:

- 1) By varying the input voltage on the brightness pin as indicated in Figure 12. Caution must be exercised when applying negative voltage to the brightness control input. Applying more than -300mV to any inverter input will cause inverter malfunction (see Absolute Maximum Ratings).
- 2) By making a resistor value change on the module. If this option is preferable, please contact the factory for application assistance.

Both methods discussed will provide a lower duty cycle operation than is necessary in a 100:1 dimming application.

Careful consideration should be made with regards to display quality

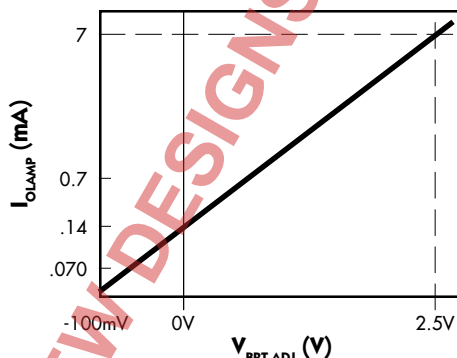

FIGURE 12 — Average Lamp Current vs. V_{BRITE} Voltage (per Lamp)

at these dimming levels. At very low brightness levels, even very small amounts of noise on the V_{BRITE} line can cause flicker on the display, so special care must be given to grounding, filtering and shielding the inverter from the digital logic and clock.

FAILSAFE FEATURE FOR MULTIPLE LAMP OPERATIONS

Our multi-output inverters are designed to keep your application operating at near normal brightness in the event that a lamp fails. This allows the display to remain "on-line" until lamp replacement is convenient.

Infinity "parallels" the lamps so that if any lamps break, most of the current is added to the remaining good lamps. CCFLs will respond with more brightness for a period of time. Operating time in this mode will be a function of the lamps age but should be typically in the order of hundreds of hours.

This operating characteristic can provide adequate display performance for a limited, but useful period of time. Shortening of the lamp life in this mode is typically not a concern as it is recommended that all lamps in a display be replaced at the same time.

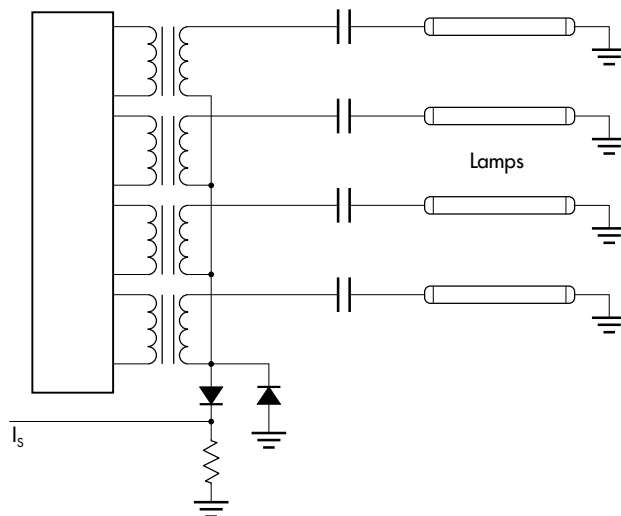

FIGURE 13 — Quad Output Stage

RangeMAX INVERTERS

Also available in Single Output LXM1611-01, LXM1612-xx-xx and Dual Output LXM1621-xx versions for multiple lamp applications.

RangeMAX and Direct Drive are trademarks of Linfinity Microelectronics Inc.

PRELIMINARY DATA - Information contained in this document is pre-production data, and is proprietary to Linfinity. It may not be modified in any way without the express written consent of Linfinity. Product referred to herein is offered in sample form only, and Linfinity reserves the right to change or discontinue this proposed product at any time.