

---

## DRF Device Mounting Procedures And Power Dissipation

George Krausse  
Phone: 541-382-8028 ext. 1200  
[gkrausse@microsemi.com](mailto:gkrausse@microsemi.com)

Dick Frey  
Phone 541-382-8028 ext. 1111  
[dfrey@microsemi.com](mailto:dfrey@microsemi.com)

Gui Choi  
Phone: 541-382-8028 ext. 1205  
[gchoi@microsemi.com](mailto:gchoi@microsemi.com)

### Introduction:

The values for power dissipation in a semiconductor device are derived from the values for the thermal resistance. Therefore, it is the package design and mounting that defines the power dissipation capability of the device. In this section we present the key elements necessary to arrive at engineering values for  $R_{\theta JHS}$  and  $R_{\theta JC}$  and define their relationship to  $T_J$ ,  $PD_C$ , and  $PD_{HS}$ . In so doing we illustrate the process we at PPG use to set these specifications.

### Definitions:

For clarity and accuracy, it is essential that we all operate with the same understanding of the definitions for terms used.

### Given:

$R_{\theta JC}$  is defined as the thermal resistance ( $R_{\theta}$ ) from the junction (J) to the case (C), with the case held at 25°C and the junction limited to  $T_{JMAX}$ .

$R_{\theta JHS}$  is defined as the thermal resistance ( $R_{\theta}$ ) from the junction (J) to the heat sink (HS), with the heat sink held at 25°C and the Junction limited to  $T_{JMAX}$ .

$PD_C$  is defined as the maximum power dissipation capability of the device with the junction limited to  $T_{JMAX}$ , and the case held at 25°C.

$PD_{HS}$  is defined as the maximum power dissipation capability of the device with the junction limited to  $T_{JMAX}$ , and the heat sink held at 25°C.

### Then:

$$PD_C = \frac{T_{Jmax} - T_{CASE}}{R_{\theta JC}} \qquad PD_{HS} = \frac{T_{Jmax} - T_{HEATSINK}}{R_{\theta JHS}}$$

These definitions are all based on two repeating limits,  $T_{JMAX}$  and the heat sink or case held at 25°C. This is a logical approach with clearly defined limits and they are the international standard, however they do not represent real world values. A cooling system that would maintain the case or heat sink at 25°C, at the power levels necessary, is possible but it would not be practical for the vast majority of commercial applications. Therefore, realistic user heat sink temperatures should be used in the calculations for power or junction temperature. In most applications the heat sink temperature will typically be 40°C to 55°C.

## Mounting instructions for Flangeless Packages

### Introduction:

The correct mounting of any power device to the heat-sink is the most important step in obtaining the manufacturer's published specifications. On average, approximately one half of the  $R_{\theta JHS}$  is the thermal resistance of the thermal compound layer which is between the bottom of the substrate and the heat sink.

**Chart 1** illustrates the  $\Delta$  Temperature for each of the materials in the vertical stack up of the DRF devices; however it is directly applicable to all power devices. The **Blue** column in Chart 1 is the total  $\Delta T$  available for the device. The **Red** column is the contribution of the thermal compound, which is more than half of the total. All conventional, devices heat sink designs face this problem. The fact that proper device heat sink mounting is a paramount concern can not be overstated.

**Chart 2** illustrates Temperature profile (DRF1400) from the die surface to the heat sink surface. This further illustrates the critical nature of the thermal compound layer. The temperature rise from the heat sink, 25°C, to the die surface, 175°C, is 150°C. The temperature rise due to the thermal compound is 118°C, or 67% of the total available temperature rise.

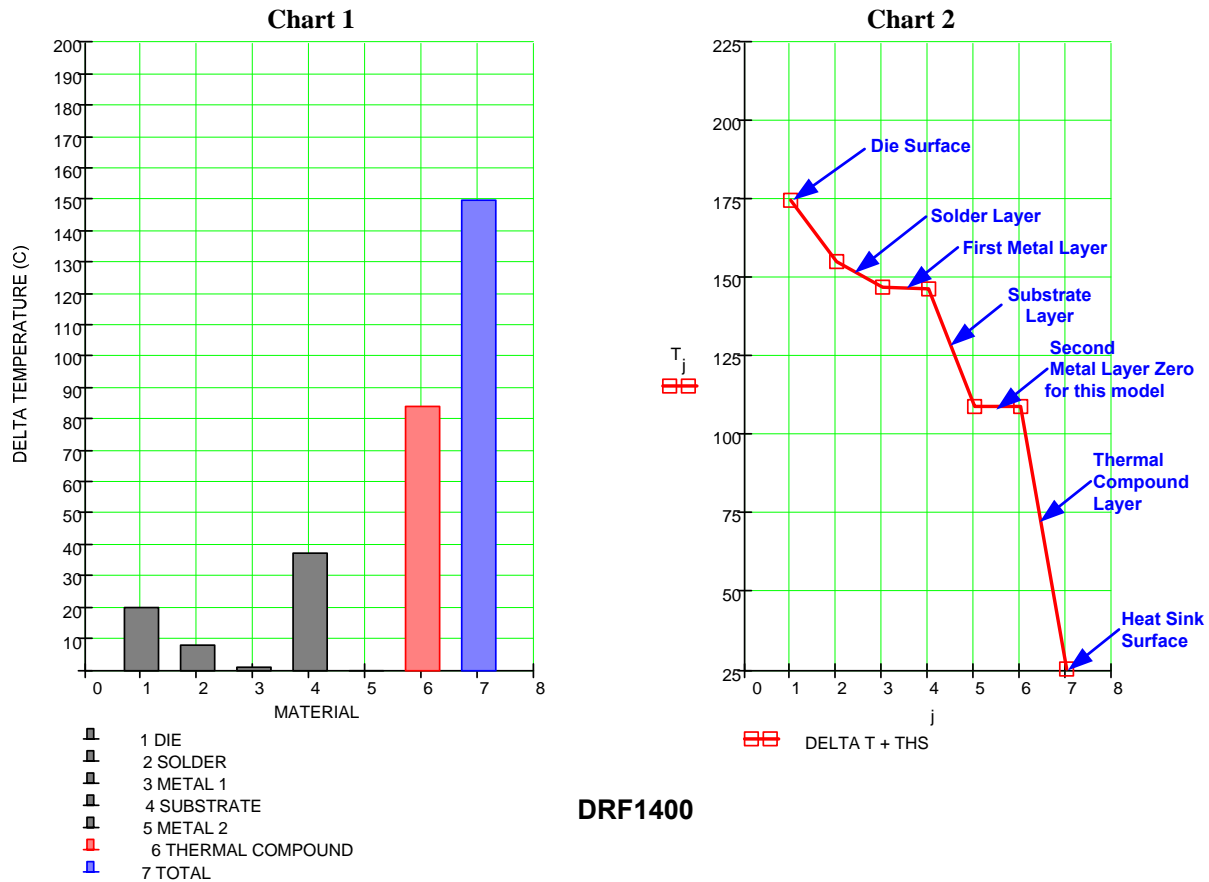

It should be noted that the  $R\theta$  of the thermal compound shown in Chart 1 is a typical value for the **Material, Application, Seating and Torque**. The assumed thickness is 0.001in, the compound is AVVID, Thermalloy, Ther-o-Link, PN 1002. These topics are addressed in more detail in the following sections.

**Device Preparation:**

The following section presents the recommended heat-sink mounting procedures for any devices in the Flangeless Package family. Figure 1 shows two PCB arrangements. The arrangement on the left is for a PCB spaced off the heat sink. The arrangement on the right is for a PCB mounted flat against the heat sink.

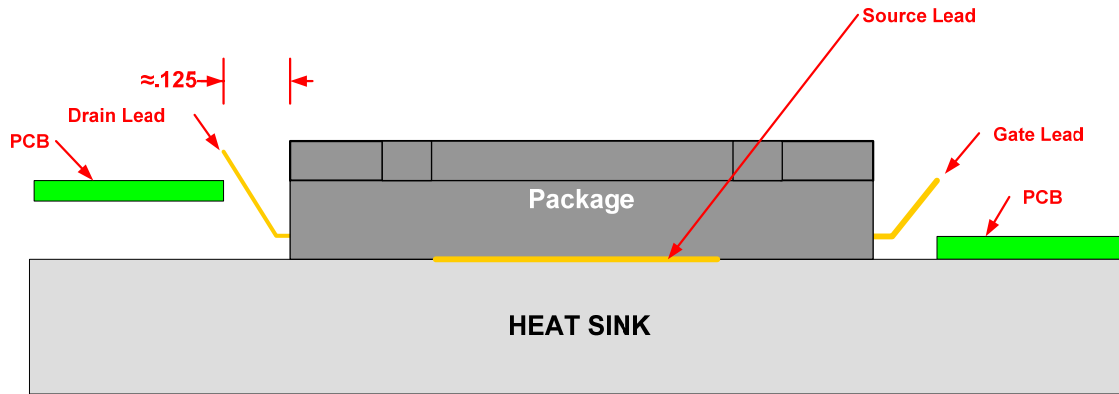

**Figure 1** Lead Bending Prior to Seating

First, bend the leads upward away from the BeO and in the direction of the top of the lid, at about a 45° angle, as illustrated in Figure 1. This prevents damage to the leads during the following processes.

The bottom surface of the device must be free of any foreign objects or material.

**Material:****Heat Sink Surface:**

1. The heat sink surface must be smooth, clean and free of nicks and burs.
2. It must be flat, < 0.5 mil/in, and finished to < 50µin.

Failure to follow the guidelines above can have a significant impact on device performance to the point of damaging the device during the mounting process or later during device operation.

The BeO bottom surface must be coated with a uniformly thin film of thermal compound. For best performance, ≈0.001in. thick is suggested. In this process either the device or the heat sink may be coated with thermal compound.

**Preferred Method for Thermal Compound Application:**

The preferred method for thermal compound application, in a production environment, is to apply the compound using a screen printer. This process insures consistent and repeatable performance.

**Application of Thermal Compound to Heat Sink by Hand:**

The thermal compound may be applied to the heat sink or the device, but not both. Figures 2 thru 4 illustrate the compound being applied to the heat sink.

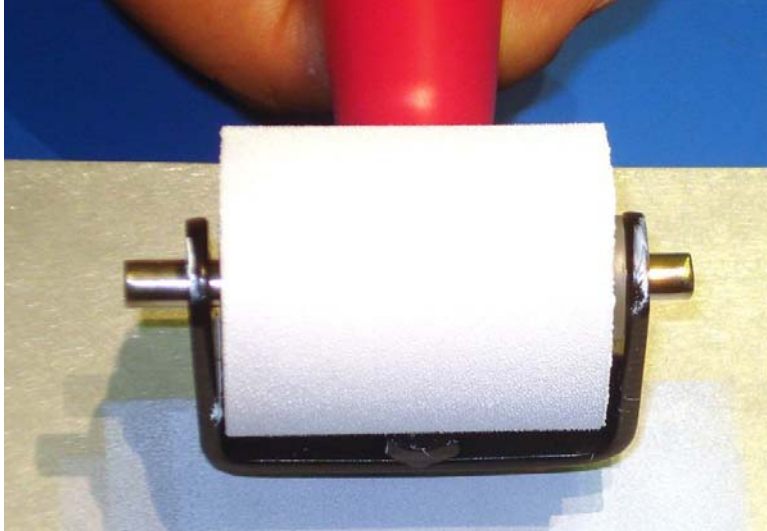

**Figure 2** Uniform Coating of Thermal Compound on Roller

The roller is coated with a very thin layer of thermal compound.

The roller is available from:  
Speed Ball Art Products  
Product #4170

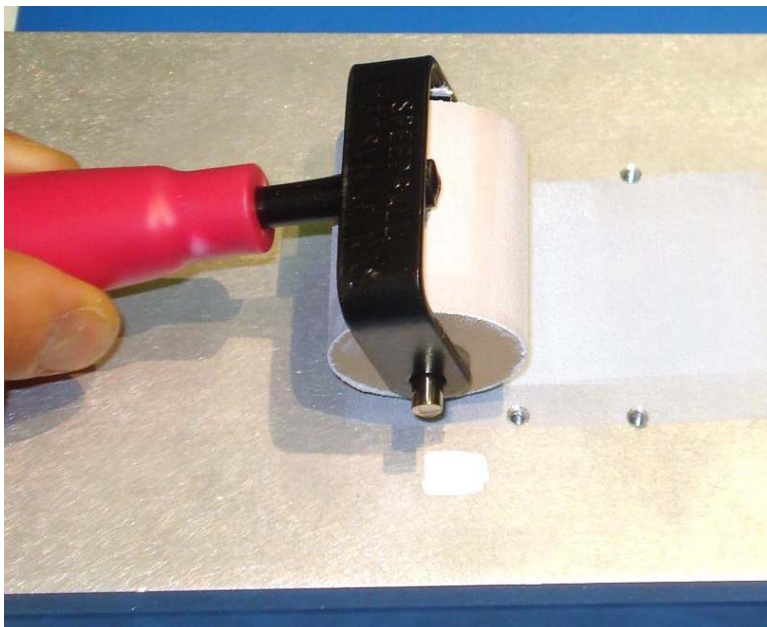

**Figure 3** Roll Left to Right 3 Times

First, we apply the compound to the heat sink in the direction parallel to the heat sink fins. This is done in three (3) complete strokes in one direction.

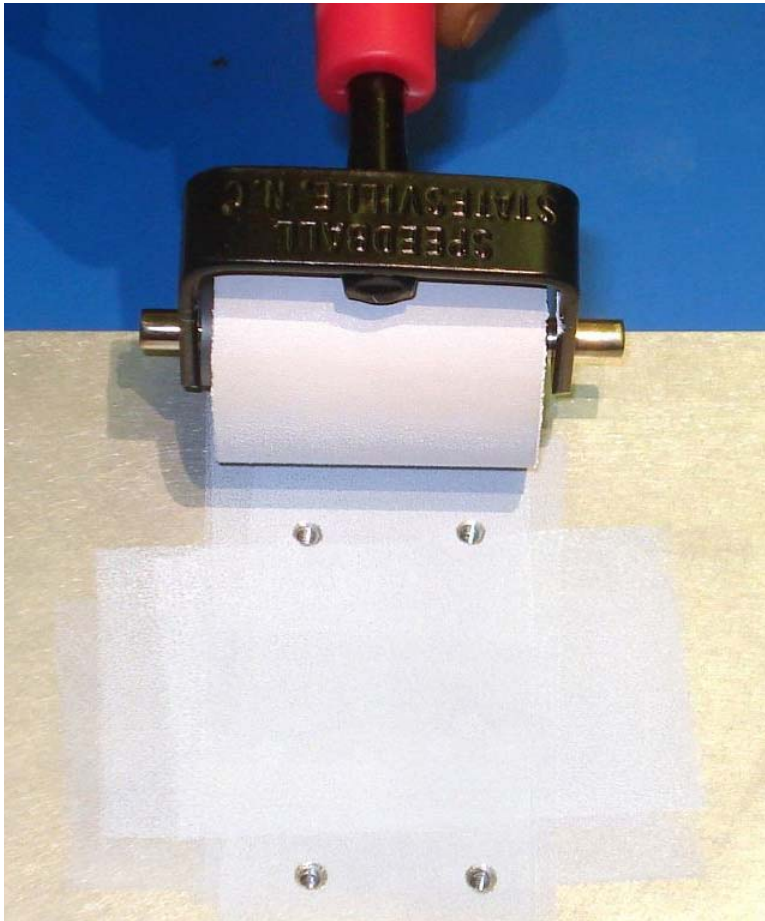

**Figure 4** Roll Up to Down 3 Times

**Figures 5 thru 8** illustrate the Thermal compound being applied to the Device.

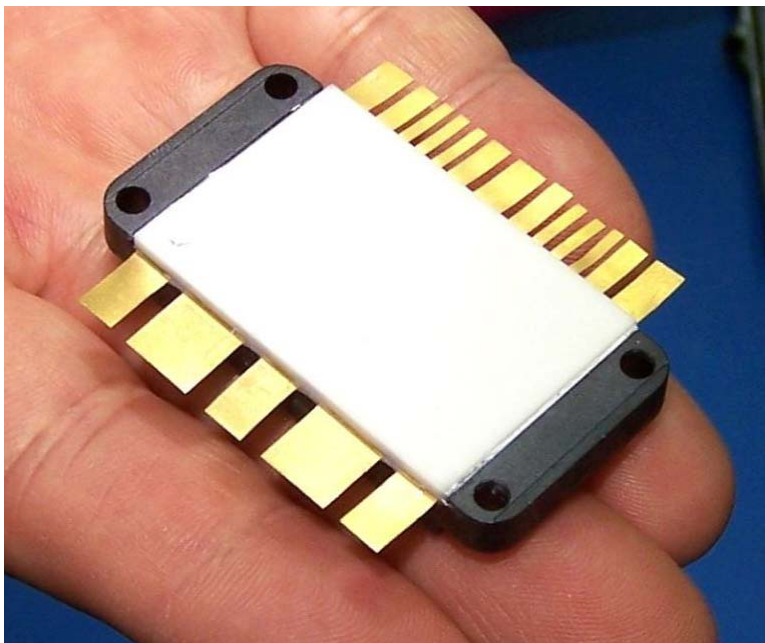

**Figure 5** Device Ready to Apply Thermal Grease

Next, we apply additional thermal compound at a 90° angle to the first coat of compound, again in three (3) strokes of the roller in one direction.

The device is clean and free of foreign matter and ready for application of the thermal grease.

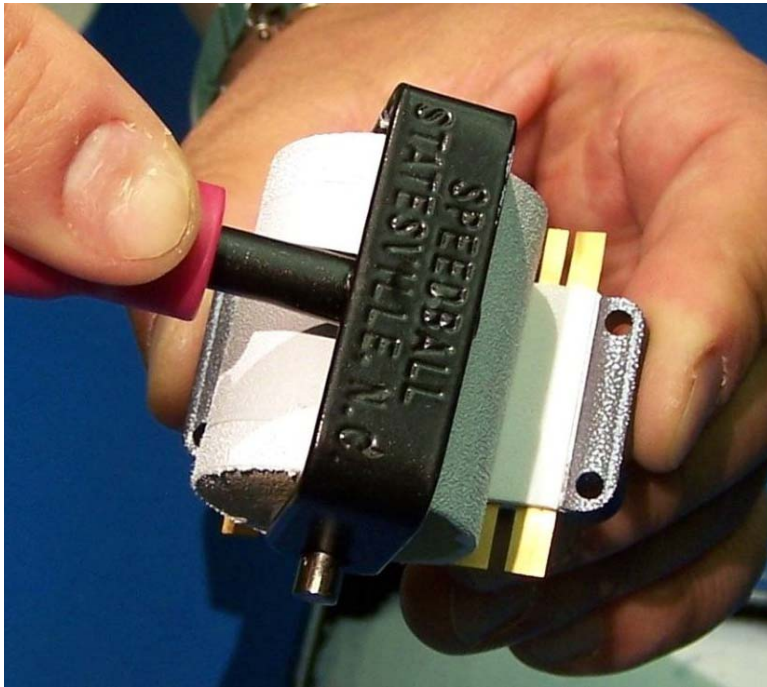

**Figure 6** Apply Grease along the Length of the Device

Apply the grease along the length of the device in three (3) strokes in one direction.

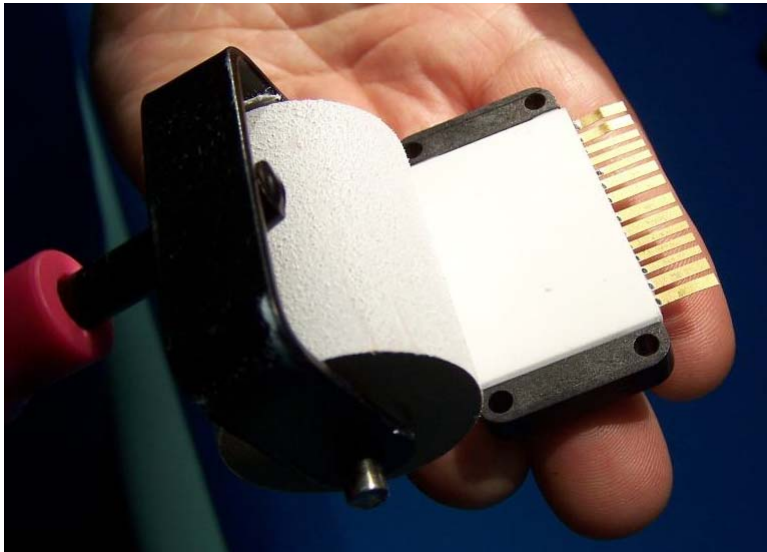

**Figure 7** Apply Grease along the Width of the Device

Apply the grease along the width of the device in three (3) strokes in one direction.

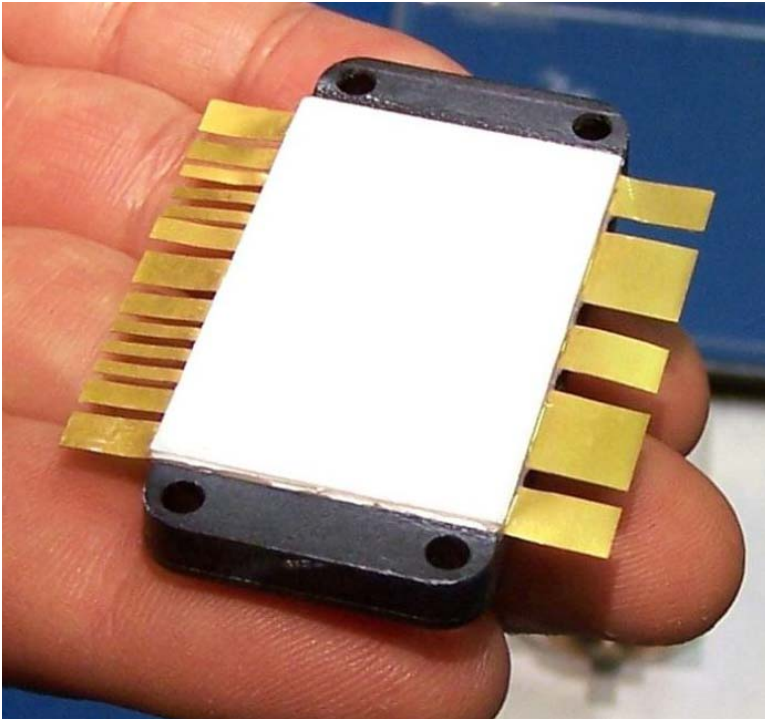

The device is now ready to mount.

**Figure 8** Device Ready to Mount

**Seating the Device:**

At this point in the attachment process, from either thermal compound application to the heat sink or thermal compound application to the device, the seating step is required.

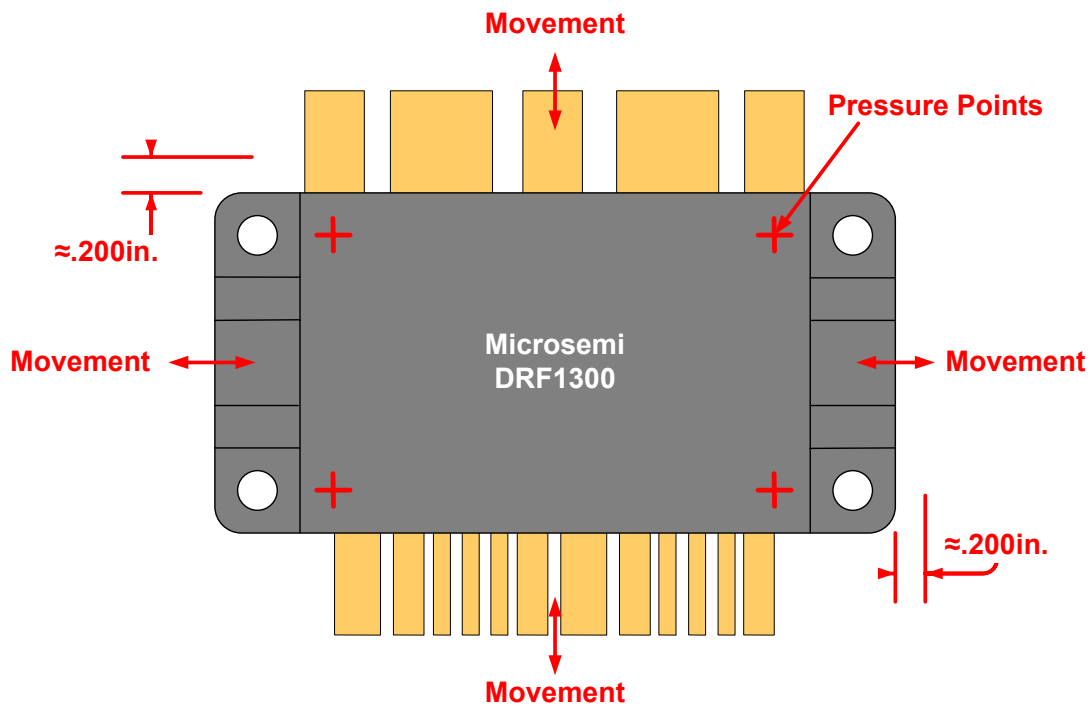

**Figure 9** Seating the Device

As illustrated by Figure 9, place the device on the heat sink and seat it using a small downward pressure and a side-to-side motion, followed by a front to back motion to remove any trapped air and excess thermal compound.

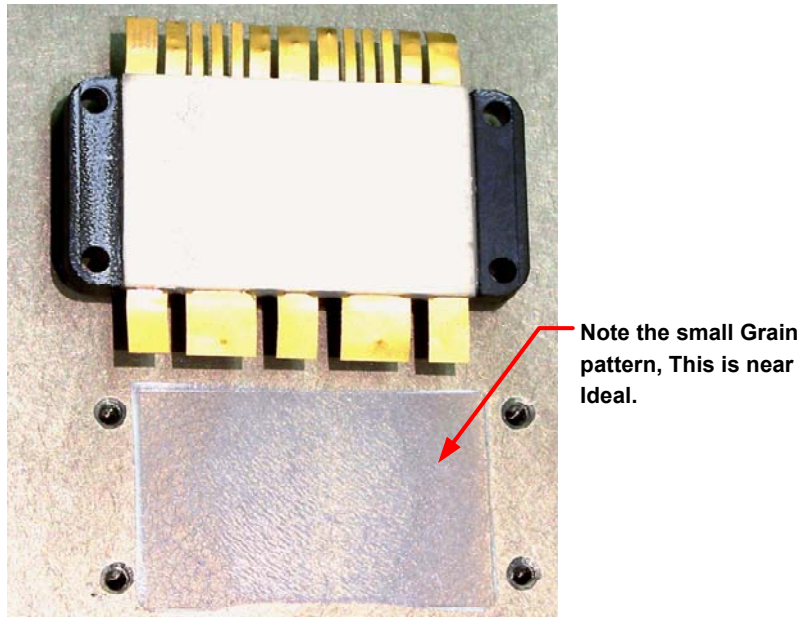
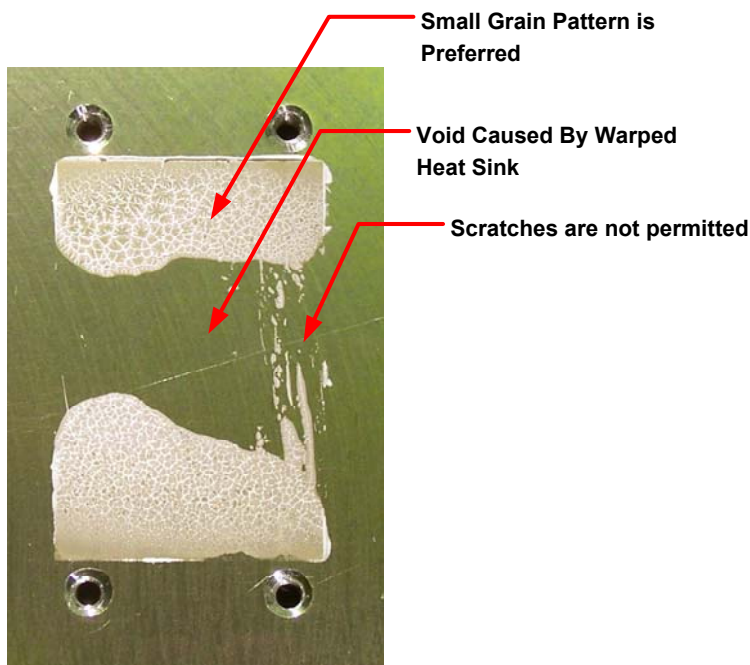

**Figure 10** Uniform Coating of Thermal Grease

Figure 10 is the same device after proper seating. The purpose of side-to-side motion is to spread the grease evenly, express as much excess compound as possible from the interface, and eliminate air pockets. Heat sink cleanliness and surface preparation are very important.

**Common Problems:**

Common problems with device mounting and the heat sink surface finish are illustrated in Figure 11.



**Figure 11** Poor Heat Sink Surface

Small Grain Patterns at the left illustrate proper thickness of the thermal compound.

This large void is most often not caused by contamination, but instead by a warped heat sink.

Scratches like the one illustrated in Figure 11 can cause a void in the thermal compound in a very bad area, the area under the power devices.

In Figure 11 above, we see the preferred small grain pattern in the upper right. This fine pattern is an indicator of thermal compound thickness, illustrated in Figure 10.

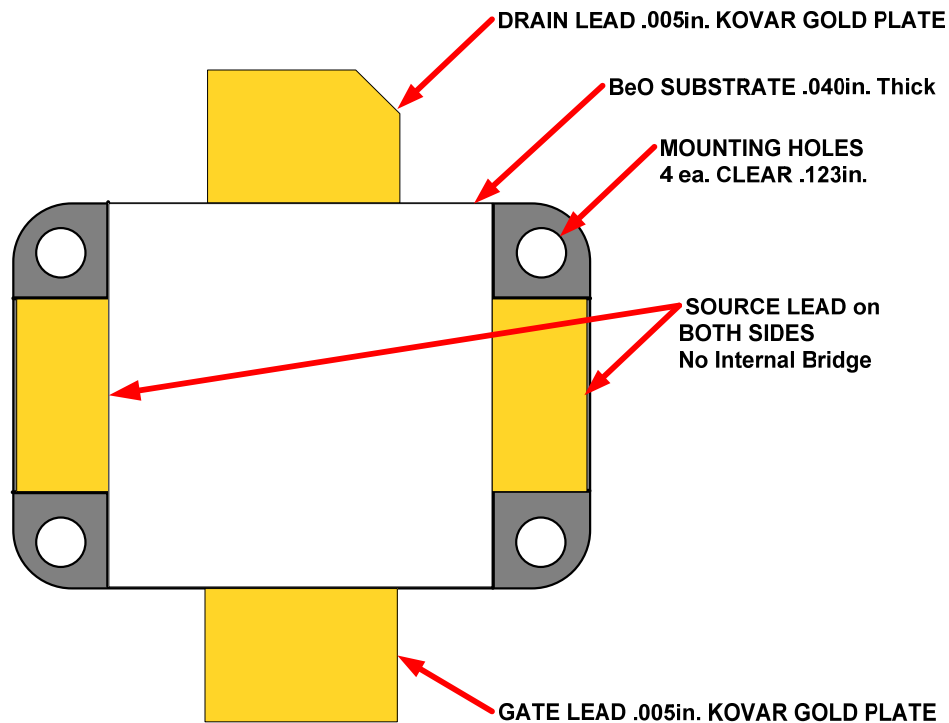

**Figure 12** Bottom View of Source lead (VRF154 shown)

For some of the Flangeless Package family (VRF154 and 157), the source terminal is on the bottom of the device as shown in Figure 12. The source leads are not directly captured by the four mounting screws and there is no internal bridge between the two.

The device is designed to compress the source lead against the heat sink, which is typical for large RF devices of this class with a base plate. The electrical resistance in this configuration is equivalent to a device with a base plate and the difference in RF gain, base plate vs. no base plate, is indistinguishable.

**Mechanical Attachment:**

The plastic/fiber-glass lid of the package is designed to have mechanical compliance. This evens or balances the pressure applied to the BeO substrate and prevents cracking the BeO substrate. The package lid is not guaranteed to be flat and parallel to the lower surface of the BeO. Therefore, the use of a flat bar placed on top of the package to apply a compressive force is not recommended. If a flat bar placed on top of the package is used to apply a compressive force, a compliant pad between the lid and the bar is required to prevent the cracking of the BeO substrate.

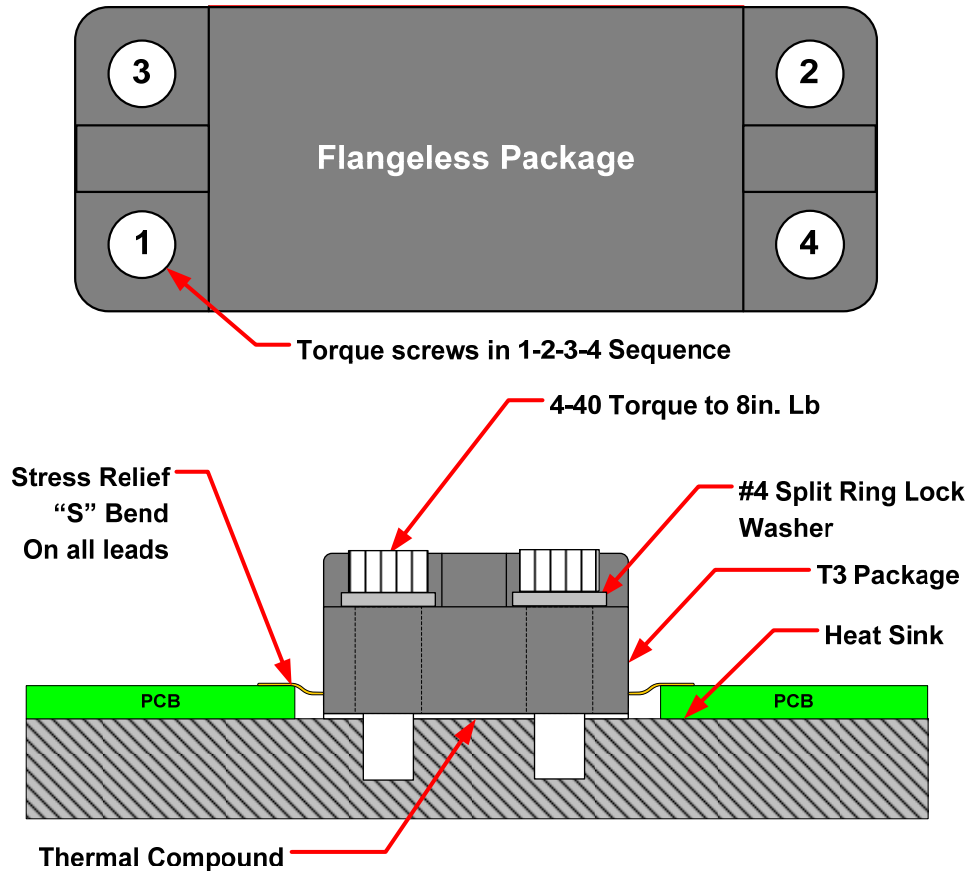
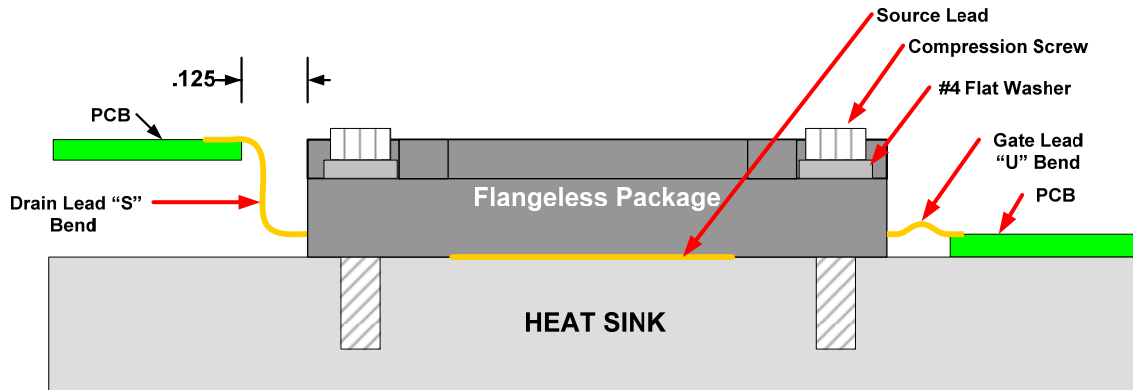

**Figure 13** Top and Side View of a T3 package.

1. The four screws (1-2-3-4), shown in Figure 13, should be installed and seated. Then torque to one-half the specification, in the sequence shown. First screw 1, then 2, 3 and finally 4.
2. Complete the process by tightening to the full specification in the same manner.
3. The Torque specification is 8in.lb.  $\pm$  1 lb.

**Lead Attachment:**

Two common lead bending approaches are the “S” bend and the “U” bend. The leads should be prepared with an “S” bend, as shown in Figure 13 for the Drain lead or the “U” bend shown for the Gate lead. The type and location of the bend used is dependant on the user’s topology, recall Figure 1.



**Figure 14** Stress Relief Bend, (VRF154 shown)

1. The leads should be soldered to the PCB after mounting the device.
2. Lead temperature must not exceed 300°C for 10s.

**Heat Sink Mounting References:**

1. Thermal Compound, AVVID, Thermalloy. Ther-o-Link, PN 1002. recommended for the DRF Devices.
2. Keratherm-Thermal Grease, KP 92, KP97, KP12 Note the R $\theta$  and pressure graph.
3. International Rectifier Application note AN-997, Mounting Guidelines for the Super-247.
4. Motorola Application Note, Mounting Considerations for Power Semiconductors AN1040.