

## 27.12 MHz, CLASS-E, 600W RF Generator using a Microsemi DRF1200 Driver/MOSFET Hybrid

Gui Choi  
Sr. Application Engineer  
Phone: 541-382-8028, ext. 1205  
[gchoi@microsemi.com](mailto:gchoi@microsemi.com)

The DRF1200/Class-E 27M Reference design is available to expedite the evaluation of the DRF1200 Driver MOSFET hybrid. This Application Note or Reference Design Kit does not represent a finished commercial-ready design. It is only a teaching tool to demonstrate the capability of the DRF1200 under 50 Ohm, flat line condition. Each reference design kit has been verified to perform to the specifications of the application note. By purchasing the reference design kit the user takes full responsibility for repair and any modification. No warranties, repair and returns will be accepted.

**The reference design kit contains lethal voltages and high power RF.  
Use safety precautions.**

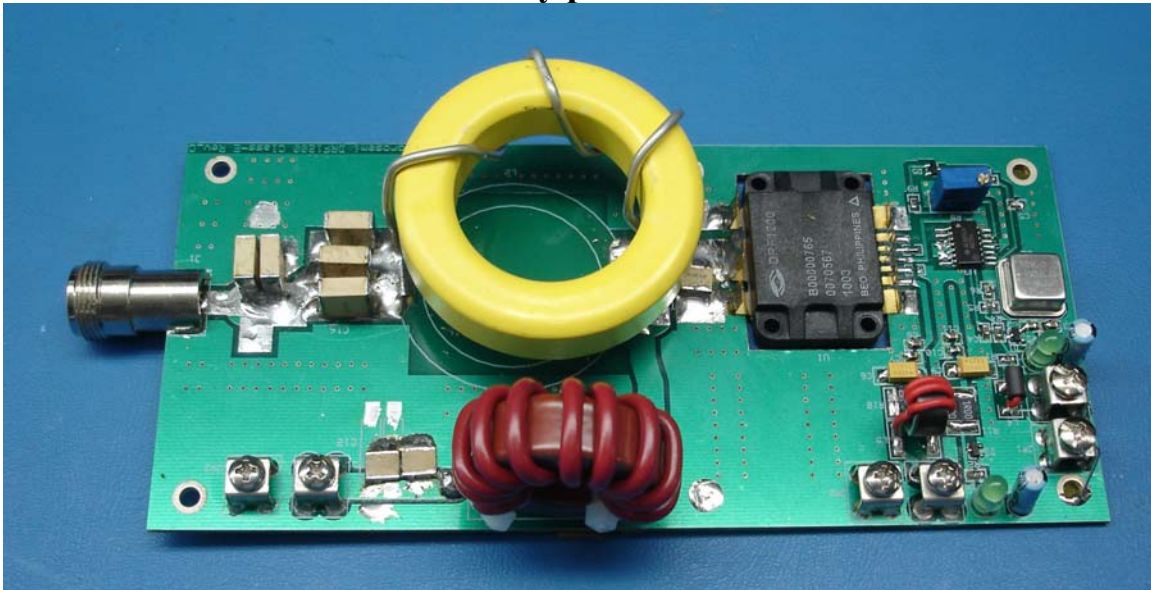

### Contents

- INTRODUCTION
- DESIGN CONSIDERATIONS
- OVERALL CONCEPT
- CIRCUIT DESCRIPTION
  - a. RF PULSE GENERATION CIRCUIT
  - b. RF OUTPUT MATCHING CIRCUIT
  - c. DC SUPPLY
- TEST REQUIREMENTS
- PERFORMANCE (DATA SUMMARY)
- CONCLUSIONS
- APPENDIX I (SCHEMATIC)
- APPENDIX II (PCB LAYOUT)
- APPENDIX III (PARTS LIST)
- REFERENCES

## INTRODUCTION

This application note discusses the design procedures and test results for a 27.12MHz, 600W, Class-E generator ideal for ISM applications. To achieve high efficiency and low cost, a Microsemi DRF1200 Driver/MOSFET was selected. The DRF1200 can generate over 600W of output power and consists of a MOSFET driver, high power MOSFET and internal bypass capacitors in an air cavity flangeless package. The flangeless package was designed to optimize reliability, provide increased flexibility while still providing a low cost solution. A reference design board (DRF1200/CLASS-E 27M) is available for purchase to facilitate the immediate evaluation of the principles of this application note.

To optimize efficiency performance, a CLASS-E RF generator was chosen. It is essential that care is taken to use adequate circuitry, clean PCB layout and good ground connections on the PCB to ensure proper output waveforms.

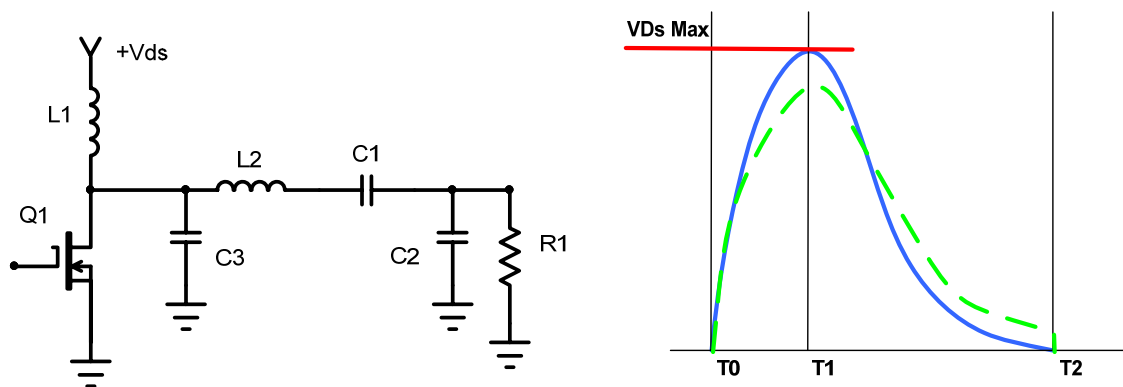

Figure 1. Simplified Class-E circuit and waveform

Figure 1. L1 is a RFC (RF Choke) that when Q1 opens causes the voltage across Q1 ( $V_{ds}$ ) to swing in excess of PS HV. C3 is selected so that combined with the  $C_{oss}$  of Q1 the drain wave form is optimally tuned as shown by the solid blue line. The dashed green line represents a suboptimum tune. See References. L2 and C1 form a resonate circuit. C2 is the Load capacitor. An external load resistance  $R1 = 50\Omega$  is used in this application and for the purpose of this discussion.

## DESIGN CONSIDERATIONS

The following issues were considered in the design of a high efficiency, high power RF generator.

- Class-E operation for high-efficiency.
- Adequate output matching circuit. Matching tools were used to achieve the required power and efficiency.
- Parts that are capable of handling RF output over several kW. This includes the bypass capacitor in the DC circuit and selecting a toroidal inductor and capacitors for output matching circuit.
- Water cooling system is highly recommended for testing.
- PCB designed for good ground connections, especially for the output matching circuit.
- PCB lay-out optimizing the isolation between power output and input signal generation circuit.

## OVERALL CONCEPT

This high efficiency RF power generator uses a DRF1200 to minimize layout parasitic and optimize efficiency for CLASS-E operation.

- RF pulse generator circuit**  
The pulse oscillator and pulse control circuit is designed to create an ISM frequency of 27.12MHz and adjust the pulse width and phase according to circuit power requirements.
- RF output matching circuit**  
The matching circuit was calculated with a RF matching software tool to maximize power transfer to 50 Ohm load. The circuit was then tuned using the inductor, capacitor and RF choke coil (RFC).

## CIRCUIT DESCRIPTIONS

### a. RF Pulse Generation

The Pulse generation circuit employs 27.12MHz TCXO and Flip Flop IC to adjust Pulse Width from 8nS to 18nS at the signal input of DRF1200. For this application, the pulse width is set at **10nS**. To minimize conductive EMI, it is crucial to use a good ground plane layout with respect to the signal lines.

### b. RF Output Matching

The DRF1200 has a switching speed of 3~4nS, BVds of 1KV and Ids of 13A max. To achieve high efficiency operation, the RF generator uses Class-E operation. At full power, the efficiency is approximately 80% at 27.12MHz. The MOSFET output capacitance was considered when tuning the external shunt capacitance to get the desired performance. See DRF1200 data sheet for output capacitance. The RF output matching circuit was designed using a RF matching tool and was optimized to achieve maximize power transfer to 50 Ohm Load. The output matching circuit is a series resistive circuit combined with a reactive circuit consisting of an "L" match Toroidal Inductor and Capacitors in series and shunt to ground.

### c. DC Supply

The PS HV DC supply input circuit utilizes a RFC and by-pass capacitors to minimize interference with AC signal. The RFC was calculated to be approximately 1k Ohm impedance at 27.12MHz using 20 turns of 18AWG wire with metal powder core. The By-pass capacitor should have a minimum 1kV rating.

## TEST REQUIREMENTS.

### a. Set-Up Diagram

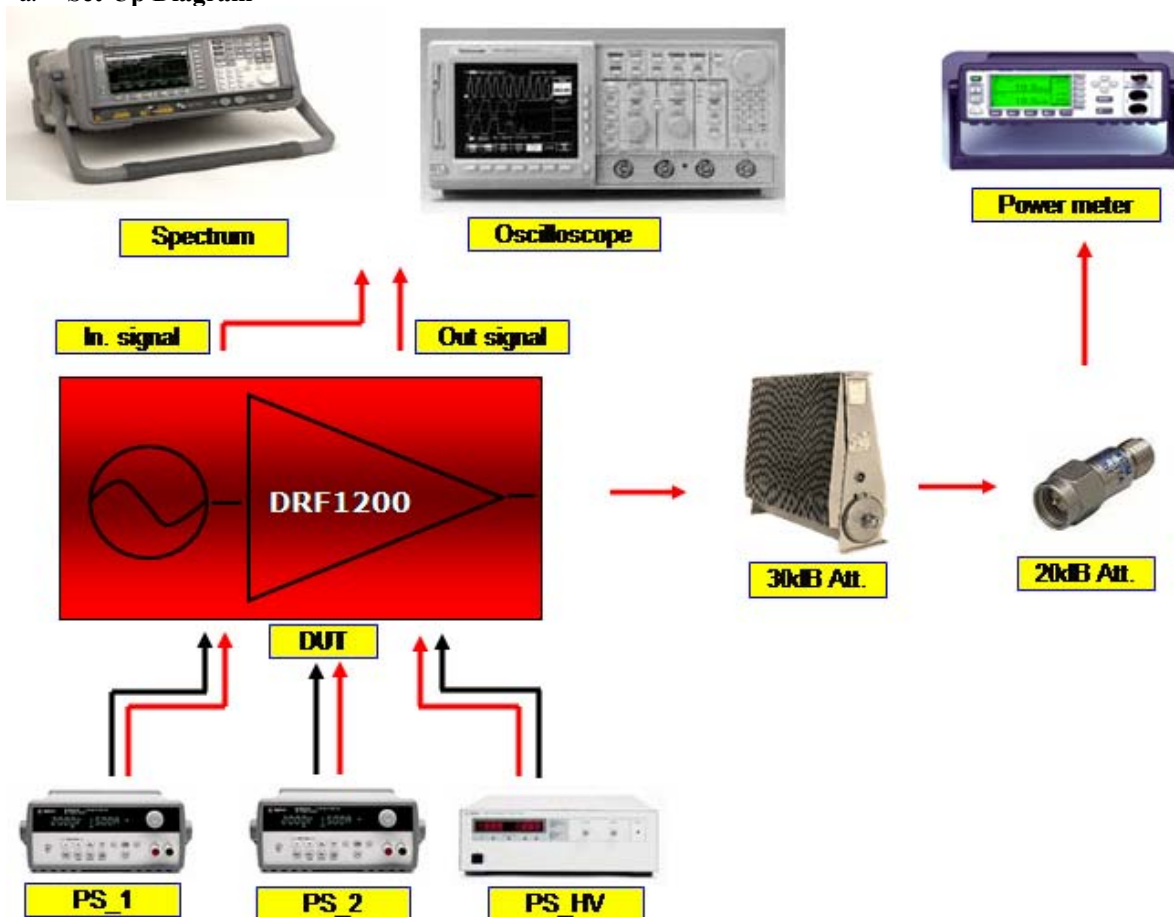

Figure 2. Test Set-Up diagram

**a. Hardware and power sequencing requirements**

- Cooling requirement: Testing is recommended to be performed using a water cooling system.
- Sequential steps for Turn-On/Turn-Off of Power Supplies.
  1. Turn on Driver power supply PS\_2 (14V via JP2).
  2. Then, turn on MOSFET supply (PS HV) and slowly increase to 50V (via JP3).
  3. Then, turn on RF pulse circuitry supply (PS\_1) (4V via JP1).
  4. While monitoring the RF power from power meter and output waveform of the Drain, ramp up MOSFET power supply (PS HV) to the values per Table 1 making sure that output is stable for each supply voltage before proceeding to the next higher voltage.
  5. To turn-off, turn power supplies off in the reverse order.
- If RF output waveform, Vds and/or RF power level from power meter fluctuate, immediately shut down PS\_HV for safety, and determine fault before resuming test.

**PERFORMANCE**
**a. Data summary**

| No\Para. | PS HV (V) | Id (A) | Pin (W) | Pout (W) | H (%) | Vpk ds (V) |
|----------|-----------|--------|---------|----------|-------|------------|
| 1        | 100       | 2.9    | 290     | 265      | 91    |            |
| 2        | 110       | 3.1    | 341     | 314      | 93    |            |
| 3        | 120       | 3.3    | 396     | 365      | 94    |            |
| 4        | 130       | 3.4    | 442     | 414      | 94    |            |
| 5        | 140       | 3.5    | 490     | 461      | 93    |            |
| 6        | 150       | 3.7    | 555     | 508      | 92    |            |
| 7        | 160       | 3.9    | 624     | 552      | 90    |            |
| 8        | 170       | 4.0    | 680     | 586      | 87    |            |
| 9        | 180       | 4.1    | 738     | 617      | 84    | 510        |

**Table 1. Power Sequencing Data Summary**

Table 1 shows the effects of varying the PS HV on MOSFET current, RF power, efficiency, and peak Vds. The chart of Efficiency vs. Pout is shown in Figure 3. The efficiency is calculated using RF power output and DC input power of the power MOSFET.

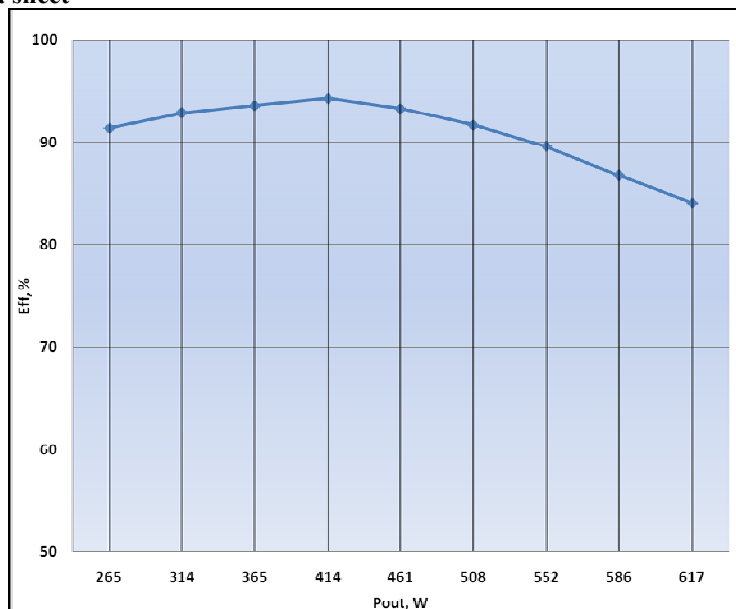
**b. Chart of data sheet**

**Figure 3. Efficiency vs Pout**

## CONCLUSIONS

This Application Note is for a reference design using a DRF1200 as a CLASS-E RF generator. The high performance DRF1200 Hybrid was used because it includes both the driver, Power MOSFET, and by-pass capacitors optimized to reduce inductance and achieve a single low cost solution. A reference design board is available to demonstrate this high efficiency of 80%, Pout 600W, Freq 27.12MHz RF generator.

The critical aspects such as the layout of components for efficient power generation, testing, and water cooling requirements are also discussed.

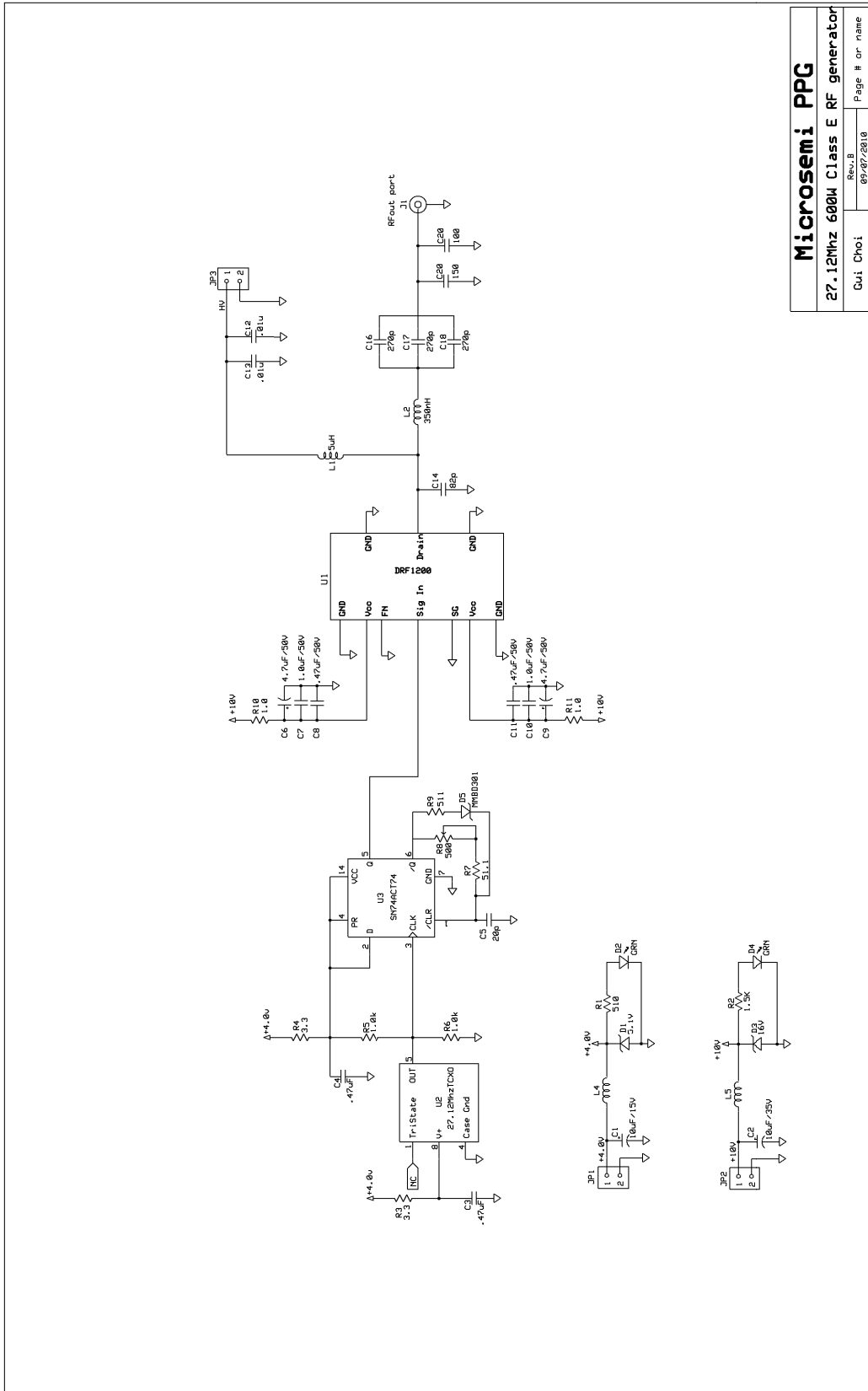
## Appendix I. Overall Schematic



|   |                |
|---|----------------|
| <b>Microsemi PPG</b>                      |                |
| <b>27.12MHz 600W Class E RF generator</b> |                |
| Qui: Choi                                 | Rev.: B        |
| g92-07/2010                               | Page 11 of 104 |

Figure 4. Overall schematic

## Appendix II. PCB Lay-out

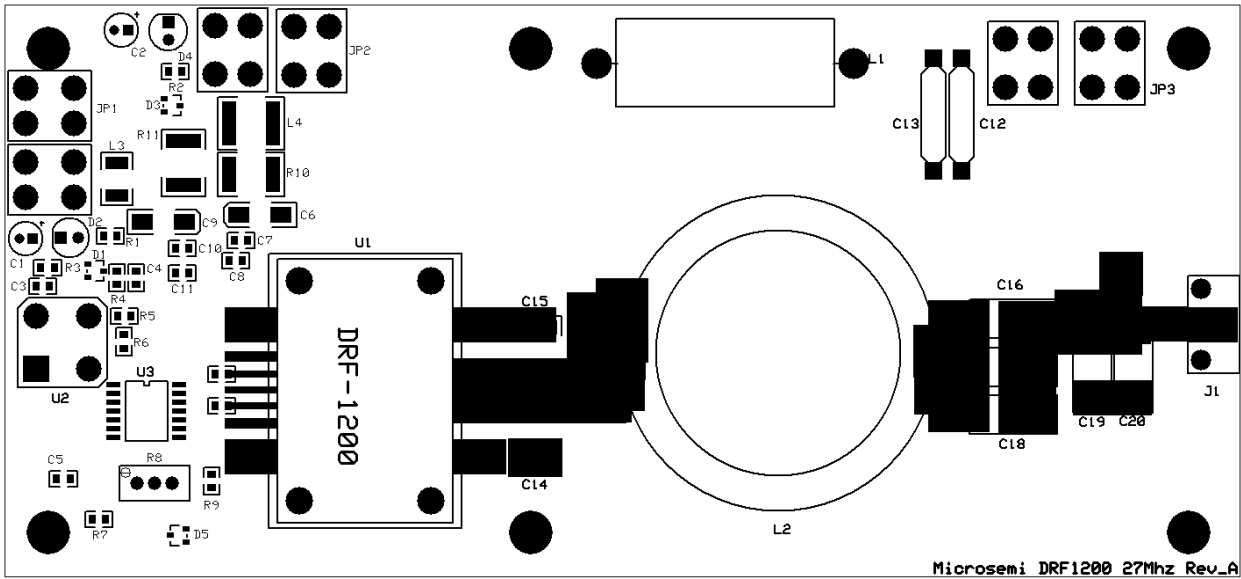

Figure 5. PCB Lay-out

### Appendix III. Parts List

| Des.   | Description                 | Size   | Supplier                | Supplier PN                     | Manuf.               | Manuf. PN                |
|--------|-----------------------------|--------|-------------------------|---------------------------------|----------------------|--------------------------|
| U1     | RF MOSFET                   | T3B    | Microsemi               | DRF1200                         | Microsemi            | DRF1200                  |
| C1, 4  | 10uF/16V(Elec_cap)          | 5*11   | Mouser                  | 140-XRL16V10-RC                 | Xicon                | 140-XRL16V10-RC          |
| C2     | 10uF/35V(Cer_cap)           | 1812   | Digi-key                | pcc2183ct-nd                    |                      |                          |
| C3     | .47uF/50V(Cer_cap)          | 805    | Digi-key                | 490-3328-1-ND                   |                      | GRM21BR71H474KA88L       |
| C5     | 10uF/35V (Cer_cap)          | 1812   | Digi-key                | pcc2183ct-nd                    |                      |                          |
| C6-9   | .47uF/50V(Cer_cap)          | 805    | Digi-key                | 490-3328-1-ND                   |                      | GRM21BR71H474KA88L       |
| C10    | 100pF/50V(Cer_cap)          | 805    | Digi-key                | PCC101CGCT-ND                   |                      |                          |
| C11    | 4.7uF/35V(Tan_cap)          | 6032   | Digi-key                | 478-1717-1-ND                   | AVX                  | TAJC475K035R             |
| C12    | 1.0uF/50V(Cer_cap)          | 805    | Digi-key                | 587-1438-1-ND                   | Taiyo Yuden          | GMK212BJ105KG-T          |
| C13    | .47uF/50V(Cer_cap)          | 805    | Digi-key                | 490-3328-1-ND                   |                      | GRM21BR71H474KA88L       |
| C14    | 4.7uF/35V(Tan_cap)          | 6032   | Digi-key                | 478-1717-1-ND                   | AVX                  | TAJC475K035R             |
| C15    | 1.0uF/50V(Cer_cap)          | 805    | Digi-key                | 587-1438-1-ND                   | Taiyo Yuden          | GMK212BJ105KG-T          |
| C16    | .47uF/50V(Cer_cap)          | 805    | Digi-key                | 490-3328-1-ND                   |                      | GRM21BR71H474KA88L       |
| C17-20 | 0.01uF/1KV                  | Disc   | Allied Elec.            | 507-0721                        | Vishay               | 562R5GAS10               |
| C22    | 82PF/2500V                  | 3838   | ATC                     | 700C820JW2500X                  | ATC                  | 700C820JW2500X           |
| C23    | 220PF/3600V                 | 3838   | ATC                     | 100E221KW3600X                  | ATC                  | 100E221KW3600X           |
| C24    | 220PF/3600V                 | 3838   | ATC                     | 100E271KW3600X                  | ATC                  | 100E271KW3600X           |
| C25    | 220PF/3600V                 | 3838   | ATC                     | 100E221KW3600X                  | ATC                  | 100E221KW3600X           |
| C26    | 150PF/3600V                 | 3838   | ATC                     | 100E221KW3600X                  | ATC                  | 100E221KW3600X           |
| C27    | 100PF/3600V                 | 3838   | ATC                     | 100E221KW3600X                  | ATC                  | 100E221KW3600X           |
| R1     | 510ohm/1/8W                 | 805    | Digi-key                | P510ATR-ND                      | Panasonic            | ERJ-6GEYJ511V            |
| R2     | 1.5Kohm 1/8W 5%             | 805    | Digi-key                | P1.5KACT-ND                     | Panasonic            | ERJ-6GEYJ152V            |
| R3     | 3.3ohm 1/8W 5%              | 805    | Digi-key                | P3.3ACT-ND                      | Panasonic            | ERJ-6GEYJ3R3V            |
| R4     | 3.3ohm 1/8W 5%              | 805    | Digi-key                | P3.3ACT-ND                      | Panasonic            | ERJ-6GEYJ3R3V            |
| R5     | 1.0K ohm 1/8W 1%            | 805    | Digi-key                | P1.0KCCCT-ND                    | Panasonic            | ERJ-ENF1001V             |
| R6     | 1.0K ohm 1/8W 1%            | 805    | Digi-key                | P1.0KCCCT-ND                    | Panasonic            | ERJ-ENF1001V             |
| R7     | 51.1ohm 1/8W 1%             | 805    | Digi-key                | P51.1CCT-ND                     | Panasonic            | ERJ-6ENF51R1V            |
| R8     | POT 500ohm 1W               | 3/8"   | Digi-key                | 3292W-501-ND                    | Bourns               | SM.3269W-1 501           |
| R9     | 511ohm 1/8W 1%              | 805    | Digi-key                | P511CCT-ND                      | Panasonic            | ERJ-6ENF5110V            |
| R10    | 1ohm 1/2W 5%                | Axial  | Digi-key                | P1.0BBCT-ND                     | Panasonic            | ERD-S1TJ1R0V             |
| R11    | 1ohm 1/2W 5%                | Axial  | Digi-key                | P1.0BBCT-ND                     | Panasonic            | ERD-S1TJ1R0V             |
| D1     | 5.1V(Diode Zener)           | SOT23  | Digi-key                | BZX84C5V1-LT1GOSCT              | On Semi.             | BZX84C5V1-7-F            |
| D2     | LED, green                  | 5mm    | Digi-key                | P375-ND                         | Panasonic            | LN31GPH                  |
| D3     | 16V (Diode Zener)           | SOT23  | Digi-key                | BZX84C16-FDICT-ND               | Diodes               | BZX84C16-7-F             |
| D4     | LED, green                  | 5mm    | Digi-key                | P375-ND                         | Panasonic            | LN31GPH                  |
| D5     | 30V/300mA(Sch.)             | SOT23  | Digi-key                | MMD301LT1GOSCT                  | On Semi.             | MMD301LT1G               |
| J1     | RFout port                  |        | Newark                  | 12M4398                         | Bomar                | 161V504E                 |
| JP1-3  | DC Terminal                 |        | Allied                  | 839-0309                        | Keystone             | 8191                     |
| L1     | Ind. w/28T AWG18            | ID:.5" | Newark                  | 05H7486                         | MCM                  | 18PE 1/4LB               |
| L2     | Toroid Inductor<br>5T 12AWG |        | Micrometals<br>Mouser   | T225-6 5 --- 2ea<br>602-289-100 | Micrometals<br>Alpha | T225-6 5<br>289          |
| L3     | Toroid Inductor<br>2T 18AWG |        | Allied Elec.<br>Digikey | 2643540302<br>A5857R-100-ND     | Fair-Rite<br>Alpha   | 2643540302<br>5857 RD005 |
| L4     | Toroid RFC<br>1T AWG22      |        | Allied Elec.<br>Digikey | 2643001301<br>A2016R-100-ND     | Fair-Rite<br>Alpha   | 2643001301<br>3051RD005  |
| L5     | Toroid RFC<br>1T AWG20      |        | Allied Elec.<br>Digikey | 2643000801<br>A2040R-100-ND     | Fair-Rite<br>Alpha   | 2643000801<br>3053RD005  |
| U2     | 27.12 MHz Osc               | Half   | Allied Elec.            | EP1100HSTSC-27.12M              | Ecliptek Co.         | EP1100HSTSC-27.120M      |
| U3     | Dual Flip-Flop IC           | 14SOP  | Digi-key                | 296-13131-1-ND                  | TI                   | SN74ACT74NSR             |

#### References

- Application Note: DRF1200 Class-E 13.56Mhz – Gui Choi
- Solid State Radio Engineering – Herbert L. Krauss and Charles W. Bostian
- Application Note: Simple and Inexpensive High Efficiency Power Amp using New APT MOSFET – Kenneth Dierberger 1994
- Application Note: PRF-1150 1KW 13.56MHz Class E RF Generator Evaluation Module – Matthew W. Vanis