

# Low profile power module combined with state of the art MOSFET switches and SiC diodes allows high frequency and very compact three-phase sinusoidal input rectifiers

Serge Bontemps<sup>(1)</sup>, Alain Calmels<sup>(1)</sup>, Simon D. Round<sup>(2)</sup>, Johann W. Kolar<sup>(2)</sup>

(1) Microsemi PPG power module Products, Chemin de Magret, F-33700 Merignac

(2) ETH Zurich, Power Electronic Systems Laboratory, Physikstrasse 3, CH-8092 Zurich

## Abstract

This paper focuses on the advantages of low profile and therefore low inductance power modules to achieve very compact power systems. Such power devices integrate state of art Super Junction MOSFET devices and latest SiC diodes for increased operating frequency and highest efficiency. A six-switch Vienna Rectifier is the topology embedded in the power module and a 10 kW output power, very compact (8.5 kW/litre) and efficient rectifier has been developed as a demonstrator by the Power Electronic Systems Laboratory at ETH Zurich.

## 1. Introduction

An increasing number of applications, especially in telecom/data server and aircraft power supplies, require high power, highly efficient, compact sinusoidal input current rectifiers. Direct 3-phase rectifiers, such as the 3-level Vienna rectifier are suitable for producing an ultra compact rectifier solution, especially for aircraft power systems since the next generation aircraft will operate with a variable frequency between 380 and 800 Hz. To achieve a minimum harmonic distortion level, this high fundamental frequency requires that the switching frequency of the rectifier is increased to values above 100 kHz. Such high frequencies only allow the use of MOSFETs as the power switches. The Vienna rectifier is a 3-level topology that reduces the voltage stress and allows 600V MOSFETs to be used from 400V line to line mains systems. When coupled with SiC diodes the switching losses are further reduced and the rectifier is able to still achieve a high efficiency even with the high switching frequencies. The performance of the converter is further improved with the very low profile SP6-P Microsemi package, which offers a height of only 12mm, by minimizing the parasitic inductance and resistance. This package features solderable terminals that allows a direct interface with a top PCB populated with decoupling capacitors and gate driver circuits.

## 2. Low profile power module integration

A six switch Vienna Rectifier (Fig.1) is selected as the topology as it has lower conduction losses since the phase current flows through only one diode in each phase during the switch conduction.

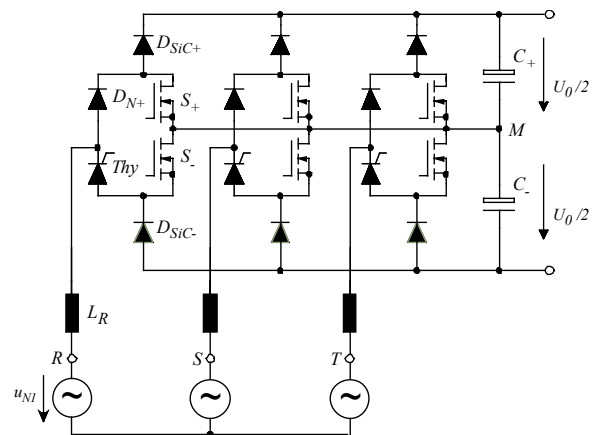

Fig.1 Circuit configuration of the 3-phase six-switch Vienna Rectifier

Near zero reverse recovery SiC diodes are connected to the positive and negative DC bus since they are subjected to the high frequency switching.

To achieve a high power density, the size of the passive components (inductors and capacitors) and the power semiconductors have to be significantly reduced. Increasing the switching frequency by a ratio of 5 to 10, compared to conventional systems, contributes to the drastic

passive components size reduction. The electrical configuration of the rectifier consists of a large number of individual components from various technologies (6 fast SiC diodes, 6 MOSFETs, 3 thyristors and 3 standard rectifier diodes). Using discretes to achieve the full configuration leads to a very wide area for the power function. In addition, the inevitable long wires for interconnecting the semiconductor devices generates wiring inductances, which increase the voltage stress of the power semiconductors and limit at the same time their switching speed. Parasitic ringing or oscillations may also appear that are difficult to cancel and/or damp out and these may affect the stability and EMC performance of the system. Therefore it makes great sense to concentrate the whole functionality inside a single package to achieve the power conversion module of the 3-phase Vienna Rectifier according to Fig.2.

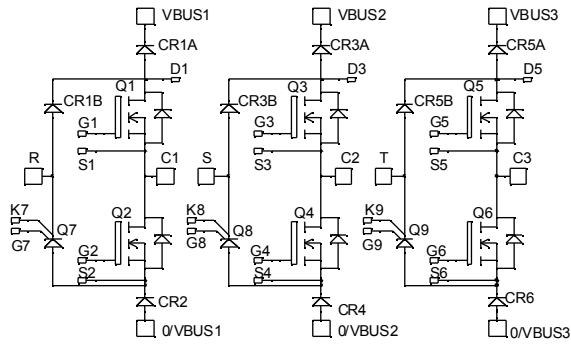

Fig.2 Power module electrical diagram

The phase control thyristors feature  $V_{RRM}=1200V$ ,  $I_{TAV}=30A$ ,  $V_{T0}=0.85V$ ,  $R_T=10\text{ m}\Omega$ . The mains rectifier diodes CR1B, CR3B and CR5B feature  $V_{RRM}=1200V$ ,  $I_{FAV}=40A$ ,  $V_{T0}=0.8V$  and  $R_T=6.5\text{ m}\Omega$ .

The Super Junction MOSFET switches are made of 600V ultra low  $R_{DSon}$  COOLMOS™ devices. With very low input capacitance they allow high frequency operation in the range of several hundred of kHz with acceptable conduction losses at high output power. Each high frequency diode is made of two 10A/600V SiC diodes dice in parallel from Cree. With a positive temperature coefficient for the VF, the static current sharing in each device is absolutely safe without the risk of thermal runaway. SiC diodes also feature essentially zero forward and reverse recovery losses that provide a significant advantage when compared to standard fast silicon diodes.

Fig.3 shows the recovery behaviour of fast recovery silicon diodes (FRED) used in a conventional boost chopper circuit.

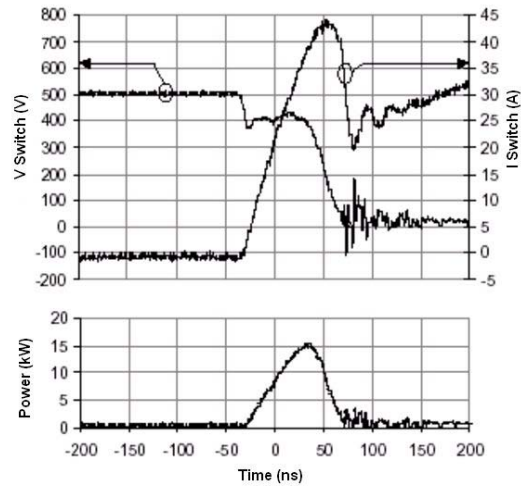

Fig.3 Voltage, current and turn on switching loss in a boost switch using a Si diode.

The diode recovery current affects significantly the switching turn on energy within the power switch when hard switched. Such behaviour will generate a significant amount of turn on losses both in the power switch and the diode, with increasing switching frequency. It has to be noted that at the end of the recovery phase some oscillations can appear, leading to a significant amount of noise in the system that may be difficult to cancel by expensive and bulky input filters.

On the other hand, Fig.4 shows the same turn on behaviour of the boost switch but with SiC diodes as the boost diode instead of the silicon devices.

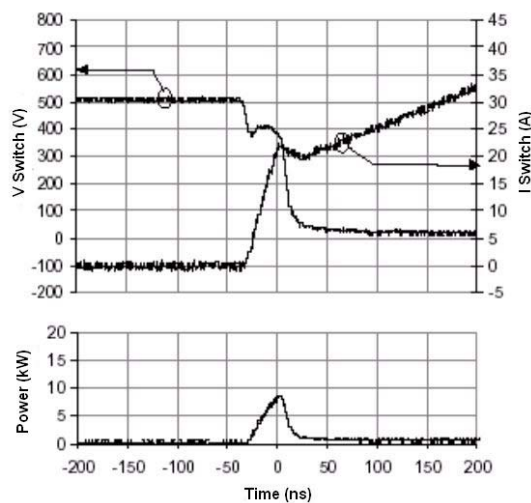

Fig.4 Voltage, current and turn on switching loss in a boost switch using a SiC diode.

Faster recovery results in much lower switching loss both in the switch and the diode. The small peak current observed while the diode turns off is due to the capacitive junction of the Schottky barrier device rather than to reverse recovery characteristics. As opposed to the configuration using conventional FRED diodes, no ringing or oscillations are measured. Such quiet switching is of prime interest to reduce the size and complexity of input filters and a great help to meet EMI/RFI requirements that become more and more severe as level of installed electrical power in aircraft increases.

The recovery behaviour of SiC devices is not only excellent at room temperature but also constant over wide temperature range. Fig.5 shows the reverse recovery behaviour of a 10A/600V Cree SiC diode versus a silicon diode of same current and voltage rating for a range of junction temperatures.

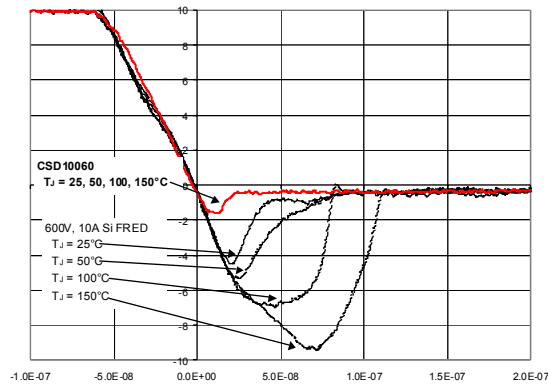

Fig.5 Reverse recovery behaviour of SiC and Si diodes for various junction temperatures.

The SiC devices exhibit temperature independent switching behaviour and offer very stable operation even up to elevated junction temperatures. Switching losses using SiC diodes will remain stable compared to silicon devices where the switching losses dramatically increase with temperature.

COOLMOS™ silicon transistors and SiC devices have also both the ability to operate at high temperatures, which could be of great interest for aircraft applications where there is a growing demand for power devices to operate in the vicinity of the engine. When the intrinsic carrier density reaches the doping level of the base material, the electrical parameters are expected to change drastically. The maximum junction temperature depends also on the breakdown voltage, 150°C for 1000V devices and up to 200°C for 100V components. The highly doping level of the base region of COOLMOS™

transistors allows higher temperature operation than with conventional silicon transistors having the same blocking voltage. COOLMOS™ devices can be safely operated up to 200°C. The intrinsic carrier density depends on the material bandgap. With three times the material bandgap of Si, SiC devices are able to operate at higher temperatures, 200°C and above (most of the time limited by packaging techniques).

It has also to be noted that both the COOLMOS™ transistors and SiC diodes exhibit very low leakage current as temperature increases, thus minimizing the power losses and improving the reliability at elevated operating temperatures. Also with three times the thermal conductivity of Si, SiC devices offer higher current densities and contribute to the size reduction of power systems.

Fig.6 shows a picture of the power module with all power semiconductors brazed onto alumina substrates. Three identical substrates are used within the package to offer good design symmetry. The substrates are soldered to a copper base plate for best heat transfer to the heat sink.

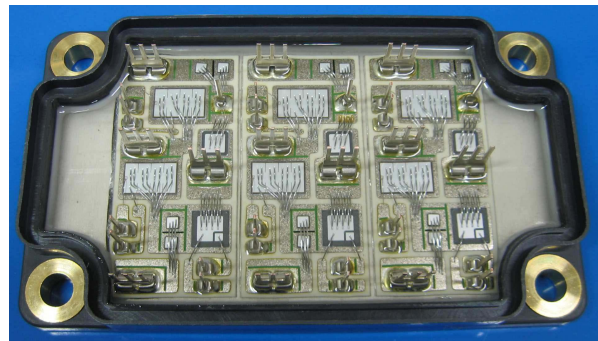

Fig.6 Picture of the open Microsemi power module

Each leg of the bridge is provided with independent Vbus and 0/VBus connections. This offers the advantage to further reduce the parasitic inductance, proportionally to the number of connections. The power connections are also placed as close as possible to the power semiconductors to minimize layout stray inductances, shorten high frequency loops and facilitate outside decoupling with capacitors placed outside the power module directly across the output terminals. The power connections are made of short and large lead frames terminated by pins to facilitate the connection to a top PCB. The module is potted with silicone gel and completed with a plastic cover (Fig.7). Such architecture meets HAST tests requirements, which are very often specified for severe aircraft environments.

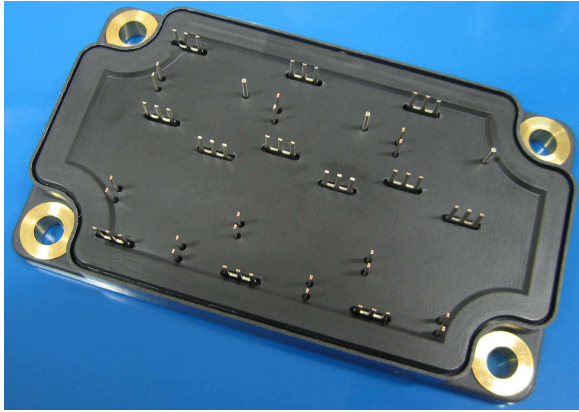

Fig.7 Photograph of the complete SP6-P power module

Thermal performance and operating temperature range can be further extended by the use of aluminium nitride substrates having a much better thermal conductivity than the existing alumina substrates. On the other hand, the use of aluminium silicon carbide (AlSiC) base plate, with one third of the density of copper, significantly reduces the weight of the power function, which has a major impact in aircraft electric systems. The AlSiC metal matrix composite material, with a Temperature Coefficient of Expansion (TCE) very close to the value of the substrates with the soldered power devices, significantly improves the temperature cycling behaviour of the power module and the overall reliability of the power system.

### 3. 3-Phase Vienna rectifier application

The power module has been implemented in an 8.5 KW/litre ( $139\text{W}/\text{in}^3$ ), 3-Phase Vienna rectifier that has a power output of 10 kW, designed by the Power Electronic Systems Laboratory of ETH Zurich.

The high power density is achieved by increasing the switching frequency to 400 kHz, which results in smaller EMI filters and boost inductors, while still maintaining a high efficiency of over 95%. The power module is attached to an optimized air-cooled heat sink, while low volume planar boost inductors are used as shown on Fig.8.

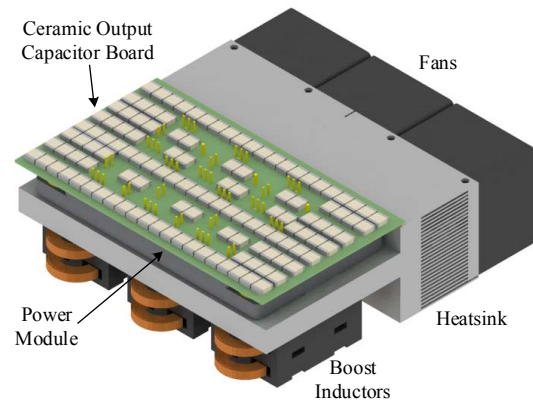

Fig.8 CAD depiction of power module assembled onto the air-cooled heat-sink.

The plastic lid of the module has been removed. A PCB with 103 ceramic capacitors (AVX 220nF 630V SMD), giving  $22.7\mu\text{F}$ , is sitting on top of the module instead of the module cover. The SMD capacitors are mounted on the bottom of the PCB to increase the top capacitance within the module but is less problematic since the capacitors would be subjected to high thermal and mechanical stress inside the module.

The rectifier is designed for low parasitic inductance and to operate with minimal output capacitance to increase the power density. The system is able to operate over a wide line-to-line input voltage range of  $320\text{ V}_{\text{RMS}}$  to  $480\text{ V}_{\text{RMS}}$ , with a nominal voltage of  $400\text{ V}_{\text{RMS}}$ . The output voltage is regulated to be 800V, which is divided into two 400V outputs if required. For an output of 10 kW, the input phase current is approximately  $15\text{ A}_{\text{RMS}}$ . A fully digital controller, with its control loop operating at the switching frequency, is used to generate the 400 kHz switching signals.

A 3-D CAD representation of the final rectifier is shown in Fig.9a and fig.9b and top and bottom views of the constructed rectifier are shown respectively in Fig.10a and Fig.10b.

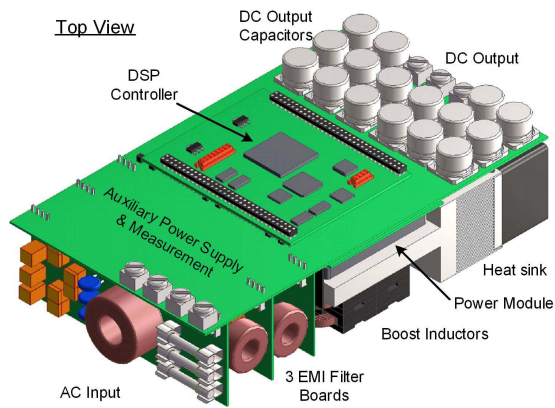

Fig.9a 3-D CAD depiction of the 8.5 kW/liter, forced air cooling Vienna Rectifier (top view)

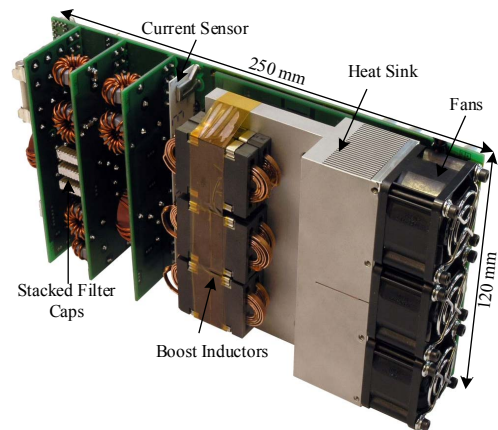

Fig.9b Bottom view photograph of the 10 kW Vienna Rectifier

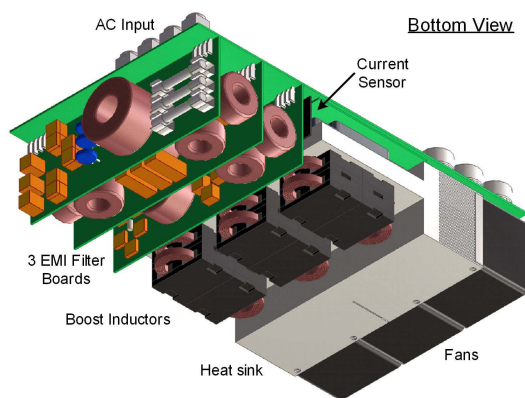

Fig.9b 3-D CAD depiction of the 8.5 kW/liter, forced air cooling Vienna Rectifier (bottom view)

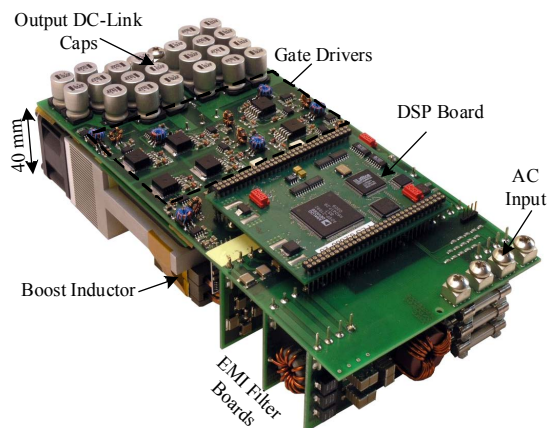

Fig.9a Top view photograph of the 10 kW Vienna Rectifier

As it can be seen, the input EMI filter occupies approximately 30% of the volume, while the cooling system takes up an additional 30%. The boost inductors, power module and interconnection and control boards fill the remaining volume. The 4-layer main PCB carries the current from the input terminals, through the EMI filter boards and current sensors to the boost inductors and the power module. Ceramic output capacitors are mounted on a separate PCB that is placed directly on top of the power module. This minimizes the output inductance between the boost diodes and the output capacitors. Additionally, electrolytic SMD output DC capacitors are mounted on top of the main PCB. The gate drivers of the six MOSFETs and the three thyristors are mounted underneath the digital controller board. Three high-bandwidth (1 MHz) magneto-resistive current sensors are placed vertically between the boost inductors and the last EMI daughter board. Input and output voltage measurement circuitry is also mounted on the main PCB. The digital controller is based upon an Analog Devices ADSP-21992 DSP and is constructed on a separate PCB that plugs directly into the main PCB. The sampling rate of the DSP is the switching frequency of 400 kHz and the DSP is programmed in assembly language. The total volume of the 10 kW 3-phase Vienna rectifier is 1200 cm<sup>3</sup> (120cm x 250cm x 4cm) for a weight of 2.1 kg.

#### 4. 3-Phase Vienna rectifier test results

The first verification of the rectifier's performance has been carried out. Fig. 10 shows the three

phase input currents and one input phase voltage when the rectifier is operated with a 230V phase voltage, a 680V output voltage and an output power of 4 kW.

At 4 kW output power the line current has a value of 5.8 ARMS with a THD of 4.75% (up to the 20<sup>th</sup> harmonic). As can be seen in the current waveforms, there is additional distortion caused at the zero crossings of the phase current. This distortion then causes distortion in the other phase currents. The control system is currently being refined to clamp the switch during the zero crossing in order to remove any sensitivity on the measurement of the phase voltage and current.

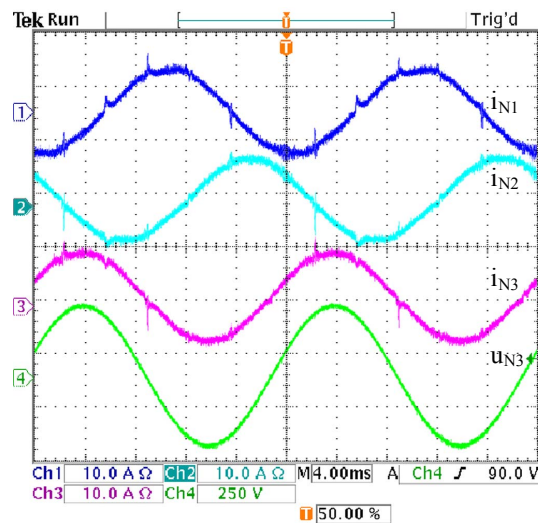

Fig.10 Experimental result showing the three phase current waveforms (Ch1 – Ch3) and the phase T input voltage (Ch4) for an output power of 4 kW.

## 5. Conclusion

The achievement of a high power, highly efficient and very compact unity power factor rectifier is the result of a careful choice of the best electrical topology, the most advanced power semiconductors, state of the art packaging techniques combined with an optimized 3-D assembly of all the functions together. With an 8.5 kW/litre power density, the 3-phase ultra compact Vienna Rectifier developed by ETH Zurich has demonstrated that the 3-level converter electrical topology is the best choice allowing the use of 600V devices for operation at 400V line-to-line where other topologies would have required 1200V devices.

600V transistors offer much better conduction and switching losses than equivalent 1200V components. When combined with SiC diodes, state of the art Super junction MOSFET devices can operate at their full speed without significant de-rating on the switched current compared to the use of silicon diodes. All the power function, with multiple components packaged in die form into the very low profile SP6-P package from Microsemi allows the advantage of the full speed characteristics of the power semiconductors to be taken without introducing any parasitic elements in the power circuit. 400 kHz operation is made possible where 100 kHz would be sufficient on a control loop point of view, resulting in a drastic reduction of the magnetic components size and the overall system volume. There is still an avenue to improve the performance of the rectifier by using Aluminium Nitride substrates to lower the junction temperature of the devices at same output power and possibly improve the efficiency or increase the output power for the same maximum operating temperature. The use of AISiC base plate instead of copper would result in a lower weight of the module and therefore of the rectifier and improve the temperature cycling behaviour of the power function should the system be submitted to fast temperature transients during the mission profile.

Special acknowledgements to the company Huettinger, in Germany, for whom similar 3-phase Vienna rectifier modules have been developed for giving its authorization to use their custom module design for the ETH Zurich project.

“COOLMOS™ comprise a new family of transistors developed by Infineon Technologies AG. “COOLMOS” is a trademark of Infineon Technologies AG”.

## 6. Bibliography

1. J. Schulz-Harder, "Advantages and New Development of direct Bonded Copper Substrates", *Microelectronics Reliability*, 2003, Vol. 43, p. 359-365.
2. L. Dupont & al. "Electrical Characterizations and evaluation of thermo-mechanical stresses of a power module dedicated to high temperature applications" *proceedings of EPE 2005, Dresde, September 2005.*
3. P. Karutz, S. D. Round, M. L. Heldwein, J. W. Kolar, "Ultra Compact Three-phase PWM Rectifier", *Proc. of 22<sup>nd</sup> IEEE Applied Power Electronics Conf. (APEC2007), Anaheim (USA), February 2007.*